

TRIUMPH

**REPLACEMENT
PARTS
CATALOGUE**

1978

BONNEVILLE 750 T140V

TIGER 750 TR7RV

INTRODUCTION

ENGINE AND FRAME NUMBERS

The engine number is located on the left side of the engine, immediately below the cylinder barrel to crankcase flange.

The frame number is located on the left side of the frame headlug, beneath the fork top lug and forward of the gasoline tank.

Both the engine and frame number should be quoted in full in any correspondence relating to the machine.

INDEX

	Page		Page
AIR CLEANER	69	KICKSTARTER	37
ALTERNATOR	9, 41	MANIFOLD	17
AUTO-ADVANCE UNIT	31	MOTOR PLATES	47
BATTERY CARRIER	85	MOTOR TORQUE STAY	47
BRAKE SWITCH	83	MUFFLERS	49
BREATHER PIPES	43	OIL PUMP	15
CAMSHAFT, INLET AND EXHAUST	9	OIL PIPES	43
CARBURETOR	27, 29	OIL PRESSURE RELEASE VALVE	15
CENTRE STAND	43	PISTONS, OVERSIZE AND RING SETS	7
CHAINS	41	PISTONS	9
CHAINCASE	41	PROP STAND	43
CLUTCH	39	PUSH RODS	19, 21, 23, 25
CLUTCH LEVER ASSEMBLY	37	REAR WHEEL	61
COIL	83	RECTIFIER	83
CONDENSERS	83	ROCKERS	19, 21, 23, 25
CONNECTING RODS	9	SIDE PANEL	69
CONTACT BREAKER	31	SPARK PLUG	83
CONTROL CABLES	77	SPEEDOMETER	81
CONTROL LEVERS	75	SPEEDOMETER GEARBOX	61
CRANKCASE	11, 13	SUSPENSION UNITS	45
CRANKSHAFT	9	SWINGING FORK	45
CYLINDERS	19, 21, 23, 25	SWITCHES	75, 85
CYLINDER HEAD	19, 21, 23, 25	SERVICE TOOLS	90
EXHAUST PIPES	49	TABLE OF STANDARD HARDWARE	88, 89
FENDERS	71	TACHOMETER	81
FLASHERS	85	TACHOMETER GEARBOX	81
FOOTRESTS	47	TAIL LAMP	73
FRAME	43	TAPPETS	17
FRONT BRAKE	57, 59	TIMING GEARS	9
FRONT FORKS	51, 53	TOOLKIT	79
FRONT WHEEL	55	TWIN SEAT	67
GASKET SETS	7	VALVES	19, 21, 23, 25
GAS TANK	67	VALVE GUIDES	19, 21, 23, 25
GEARBOX	33, 35, 37	VALVE GUIDE SETS	7
HANDLEBAR	75	WIRING HARNESS	87
HEADLAMP	85	ZENER DIODE	83
HORN	83		

HOW TO USE THIS PARTS CATALOGUE

First consult the index on Page 3 for the parts or group of parts which you wish to locate. When you have located the parts make sure from the end columns that the part you have located does apply to your machine.

List the quantities required as single units; do not ask for "2 pairs" or "3 dozen".

In case of painted items always state the color required. Painted parts are available only in the colors or alternatives specified for that model of that particular year.

PLEASE NOTE

THROUGHOUT THIS LIST, ASSEMBLIES ARE PRINTED IN CAPITALS AND THE COMPONENTS INCLUDED IN THAT ASSEMBLY ARE INDENTED IN THE DESCRIPTION COLUMN, REVERTING TO THE ORIGINAL ALIGNMENT WHEN THE ASSEMBLY IS COMPLETE. TO ORDER THE COMPLETE ASSEMBLY IT IS NECESSARY ONLY TO QUOTE THE ASSEMBLY NUMBER. ANY COMPONENT PARTS LISTED MAY ALSO BE OBTAINED SEPARATELY IF REQUIRED.

SPECIAL WORKSHOP TOOLS

A COMPLETE LIST OF WORKSHOP TOOLS CAN BE MADE AVAILABLE BY EITHER CONTACTING YOUR DEALER OR APPLYING DIRECT TO THE TRIUMPH SERVICE DEPARTMENT. IN MOST CASES THESE TOOLS ARE VERY COSTLY AS THEY ARE MADE ENTIRELY FOR WORKSHOP USE, AND THEREFORE, IT IS NOT RECOMMENDED THAT THE PRIVATE OWNER PURCHASES THE TOOLS IN ORDER TO AID SERVICING THE MACHINE ONCE OR TWICE ONLY. IN THESE CIRCUMSTANCES IT IS FAR MORE ECONOMICAL TO GET IN TOUCH WITH A RECOGNISED DEALER.

UNIFIED THREAD FORM

NEW PARTS HAVING THREADED FIXINGS INTRODUCED IN THIS CATALOGUE HAVE THE UNIFIED FORM OF SCREW THREADS. THIS CHANGEOVER WILL BE CONTINUED AS AND WHEN NEW PARTS ARE INTRODUCED. EVEN WHERE PARTS ARE SIMILAR IN APPEARANCE NEW PART NUMBERS WILL BE ALLOCATED TO IDENTIFY THE UNIFIED THREADS. ALL NUTS, BOLTS AND STUDS HAVING THIS THREAD ARE IDENTIFIED BY MARKINGS. BOLTS HAVE A CIRCULAR RECESS IN THEIR HEADS, STUDS A CIRCULAR GROOVE ON THE END, AND NUTS HAVE INTERLOCKING CIRCLES ON THE SIDE.

PARTS SPECIAL TO PARTICULAR MARKETS ARE IDENTIFIED IN 'REMARKS' COLUMN, OTHERWISE PARTS ARE COMMON TO ALL MARKETS.

WHERE MAKERS PART NUMBERS ONLY ARE SHOWN FOR REFERENCE, PARTS MUST BE OBTAINED DIRECT FROM THE MAKERS OR THEIR DISTRIBUTORS.

OVERSIZE PISTONS AND RINGS

Piston assembly 8.6 : 1	+0.010	71-3686
Piston assembly 7.9 : 1	+0.010	71-3995
Compression ring	+0.010	71-3691
Scraper ring	+0.010	71-3696
Piston assembly 8.6 : 1	+0.020	71-3687
Piston assembly 7.9 : 1	+0.020	71-3996
Compression ring	+0.020	71-3692
Scraper ring	+0.020	71-3697
Piston assembly 8.6 : 1	+0.040	71-3689
Piston assembly 7.9 : 1	+0.040	71-3998
Compression ring	+0.040	71-3694
Scraper ring	+0.040	71-3699

PISTON RING SETS

Ring set - 76mm	Std.	99-3789
Ring set - 76mm	+0.010	99-3790
Ring set - 76mm	+0.020	99-3791
Ring set - 76mm	+0.040	99-3792

VALVE GUIDE SETS

Valve guide set	Std.	99-3793
Valve guide set	+0.002	99-3794
Valve guide set	+0.004	99-3795
Valve guide set	+0.006	99-3796

GASKET SETS

Decoke		99-7001
Overhaul		99-7002

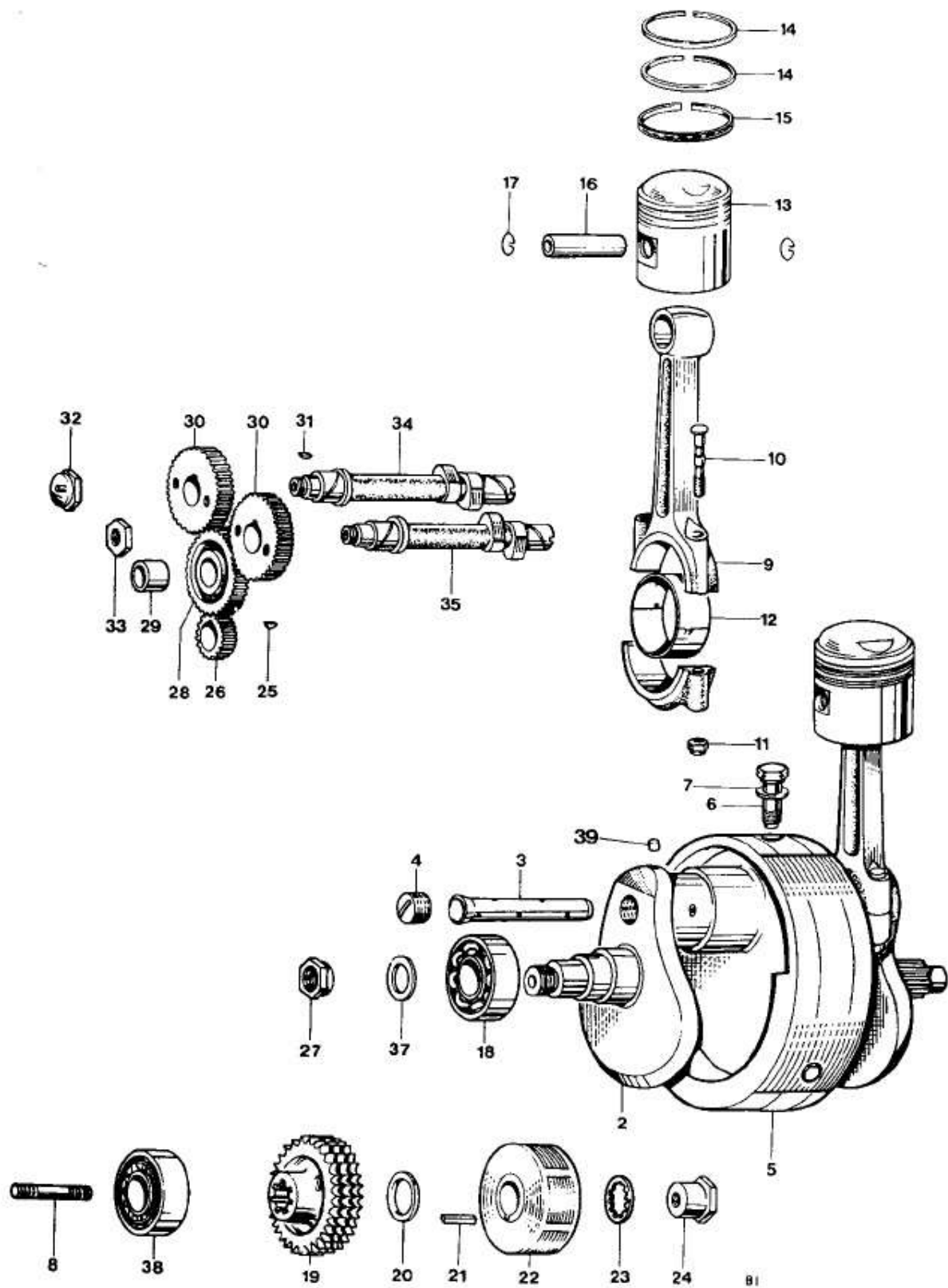

Fig. 1. CRANKSHAFT AND CONNECTING RODS

CRANKSHAFT AND CONNECTING RODS

Ref. No.	Part No.	Description	Quantity	Remarks
1	71-3030	CRANKSHAFT AND FLYWHEEL ASSEMBLY	1	
2	71-3298	CRANKSHAFT C/W. OIL TUBE	1	
3	70-3903	Oil tube	1	
4	71-2800	Screwed plug	1	
5	71-2425	Flywheel	1	
6	71-3552	Flywheel bolt	3	
7	71-1003	Washer	3	
8	21-2183	Crankshaft stud (1 3/8 in. O.A.)	1	
9	71-3006	CONNECTING ROD	2	
10	70-9914	Connecting rod bolt	4	
11	60-3761	Self locking nut	4	
12	70-3586	Big end bearing (Available in -.010 in. and -.020 in. undersizes)	4	
13	71-3778	PISTON COMPLETE (7.9 : 1)	2	
14	71-3690	Taper compression ring	4	
15	71-3695	Oil control ring	2	
16	71-3354	Gudgeon pin	2	
17	71-3700	Circlip	4	
18	60-4167	Main bearing, right (RHP5/6306)	1	
19	71-3542	Motor sprocket, 29 teeth Triplex	1	
20	71-3544	Distance piece	1	
21	71-0082	Rotor key	1	
22	99-0739	Rotor	1	Lucas 54213901
23	21-7024	Fan disc lock washer	1	
24	21-2182	Nut	1	
25	70-1580	Key	1	
26	70-4564	Timing pinion	1	
27	71-2877	Nut	1	
28	70-6159	INTERMEDIATE WHEEL	1	
29	70-0400	Intermediate wheel bush	1	
30	71-3666	Camshaft pinion	2	
31	70-1558	Camshaft key	2	
32	71-1007	Inlet camshaft nut	1	
33	70-6523	Exhaust camshaft nut	1	
34	71-7016	Inlet camshaft	1	
35	71-7017	EXHAUST CAMSHAFT	1	
37	70-3300	Clamping washer	1	
38	70-2879	Main bearing, left (RM11L)	1	
39	70-3902	Plug, crankshaft oilway	1	
Not illus.	71-2663	Spacer	1	
Not illus.	70-8038	Shim (0.010 in.)	} Engine sprocket	As required (up to 4)
Not illus.	71-2660	Shim (0.030 in.)		

* Use 60-0524 Loctite Sealant

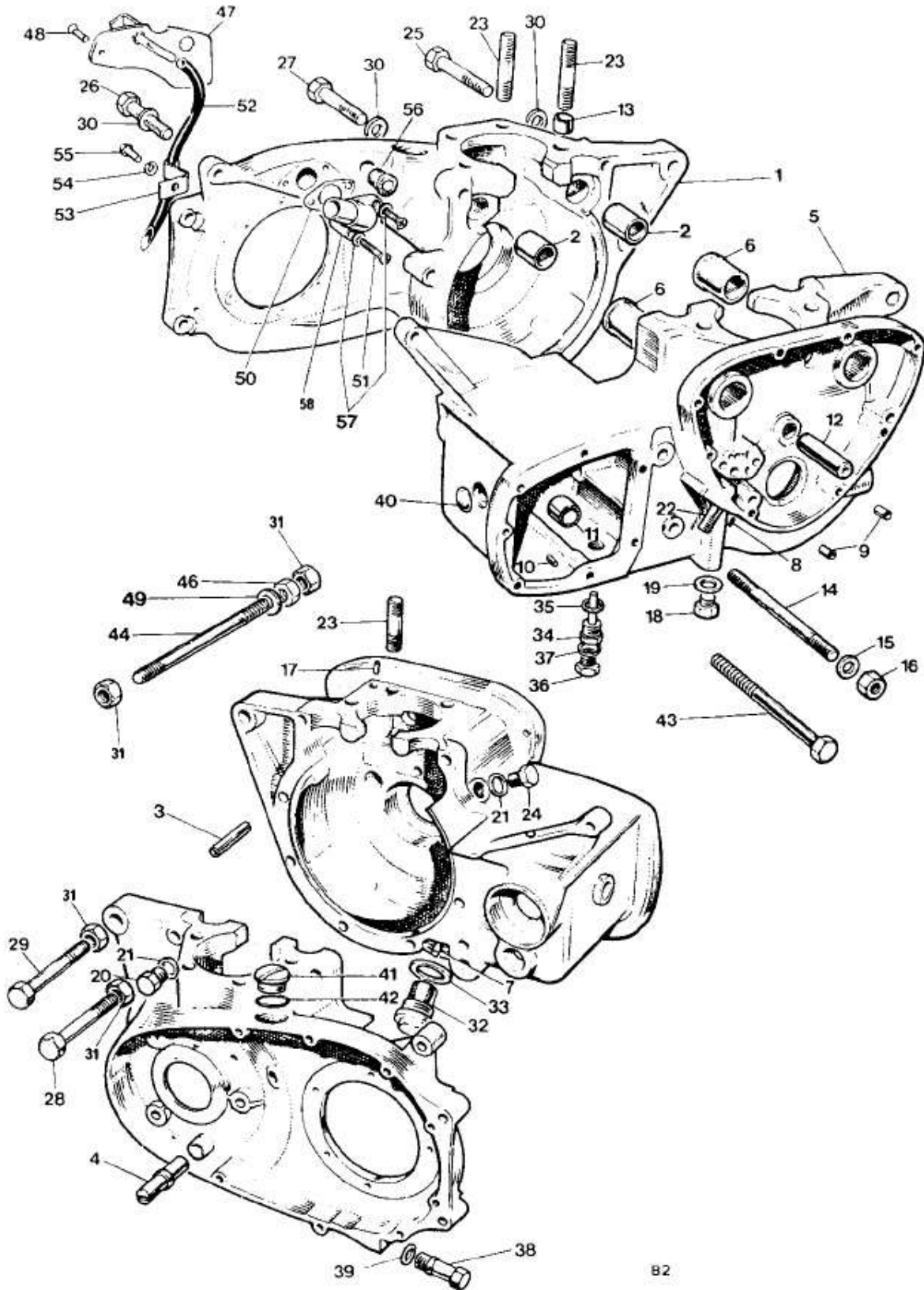

Fig. 2 CRANKCASE

CRANKCASE

Ref. No.	Part No.	Description	Quantity	Remarks
1		*CRANKCASE DRIVE SIDE	1	Reference only
2	71-0287	Camshaft bush L.H.	2	
3	71-5789	Hollow dowel, crankcase joint	1	
4	70-5088	Chain tensioner abutment	1	
5		*CRANKCASE TIMING SIDE	1	Reference only
6	71-0288	Camshaft bush R.H.	2	
7	70-4538	Suckeage pipe	Reference only	
8	70-6386	Locating peg (at oil pipes)	Reference only	
9	57-0989	Hollow dowel	2	
10	57-0912	Locating peg (L/S at thrust washer)	1	
11	57-1606	Needle roller bearing, layshaft	1	
12	70-0375	Intermediate wheel spindle	1	
13	70-8751	Hollow dowel, cylinder base	2	
14	14-1445	Stud, rear	1	
15	60-4246	Plain washer	2	
16	14-1303	Nut	1	
17	70-1532	Hollow dowel, tappet oil feed	2	
18	70-9330	Oilway plug	1	
19	82-1880	Copper washer	1	
20	21-1871	Tachometer drive plug (L.H. thread)	1	
21	37-3761	'O' ring, ignition timing hole plug	1	
22	21-1863	Oil pipe stud	1	
23	21-1865	Cylinder stud	4	
23	71-3013	Cylinder stud	4	
24	21-1872	Plug, timing hole	1	
25	21-1870	Bolt, rear	1	
26	14-6220	Bolt, top rear	1	
27	14-6223	Bolt, top front	1	
28	14-0230	Bolt, long - crankcase halves	1	
29	21-1823	Bolt, short - crankcase halves	2	
30	60-2330	Plain washer	10	
31	14-1302	Nut	5	
32	70-9336	Crankcase filter	1	
33	70-8782	"O" Ring	1	
34	57-2167	Drain plug (with level tube)	1	
35	57-1257	Fibre washer	1	
36	21-0543	Level plug	1	
37	70-2441	Copper washer	1	
38	57-2259	Drain and adjuster plug	1	
39	70-7431	'O' ring	1	
40	57-1920	Blanking plug	Reference only	
41	57-2166	Filler plug	2	
42	70-8782	'O' ring	2	
43	14-6242	Bolt, rear - crankcase halves	1	
44	21-0669	Stud, crankcase halves	1	
46	14-0402	Nut, exhaust ties	2	
47	71-1072	Breather cover plate assembly	1	
48	71-1075	Screw	1	
49	60-2428	Spring washer	2	
*	71-7021	CRANKCASE TS/DS	1	

* NOTE CRANKCASES ARE SUPPLIED ONLY AS MATCHED PAIRS PART No. 71-7021

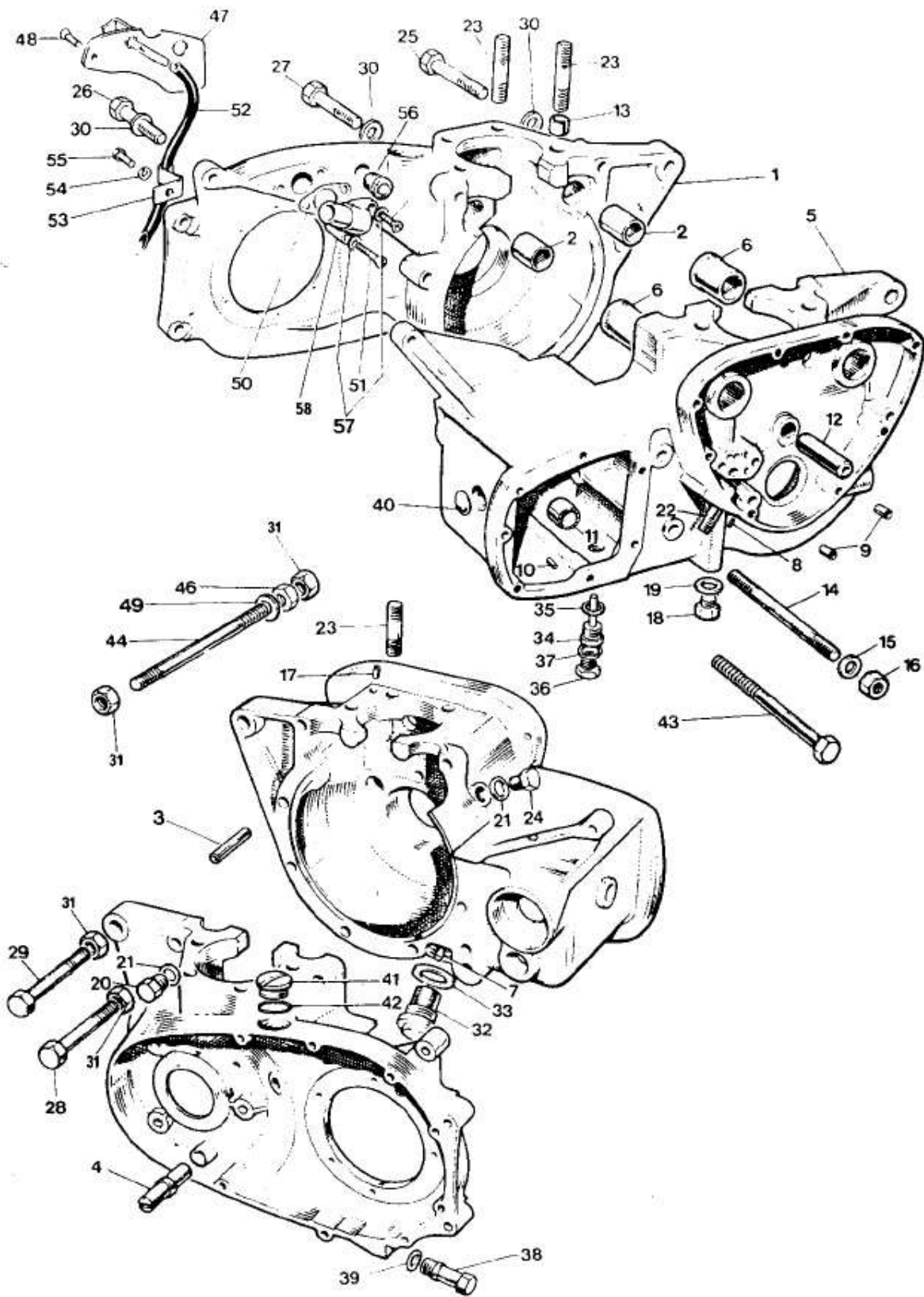

Fig. 2 CRANKCASE

CRANKCASE (continued)

Ref. No.	Part No.	Description	Quantity	Remarks
50	71-1460	Joint washer	1	
51	70-7354	Screw	2	
52	71-1078	Tube, primary chain oiler	1	
53	70-4705	Clip	1	
54	60-4250	Spring washer	1	
55	14-6101	Bolt (7/16 in. U.H.)	1	
56	71-1345	Grommet, alternator leads - external	1	
57	70-6559	Washer outlet stub screw	2	
58	71-4044	Outlet stub	1	

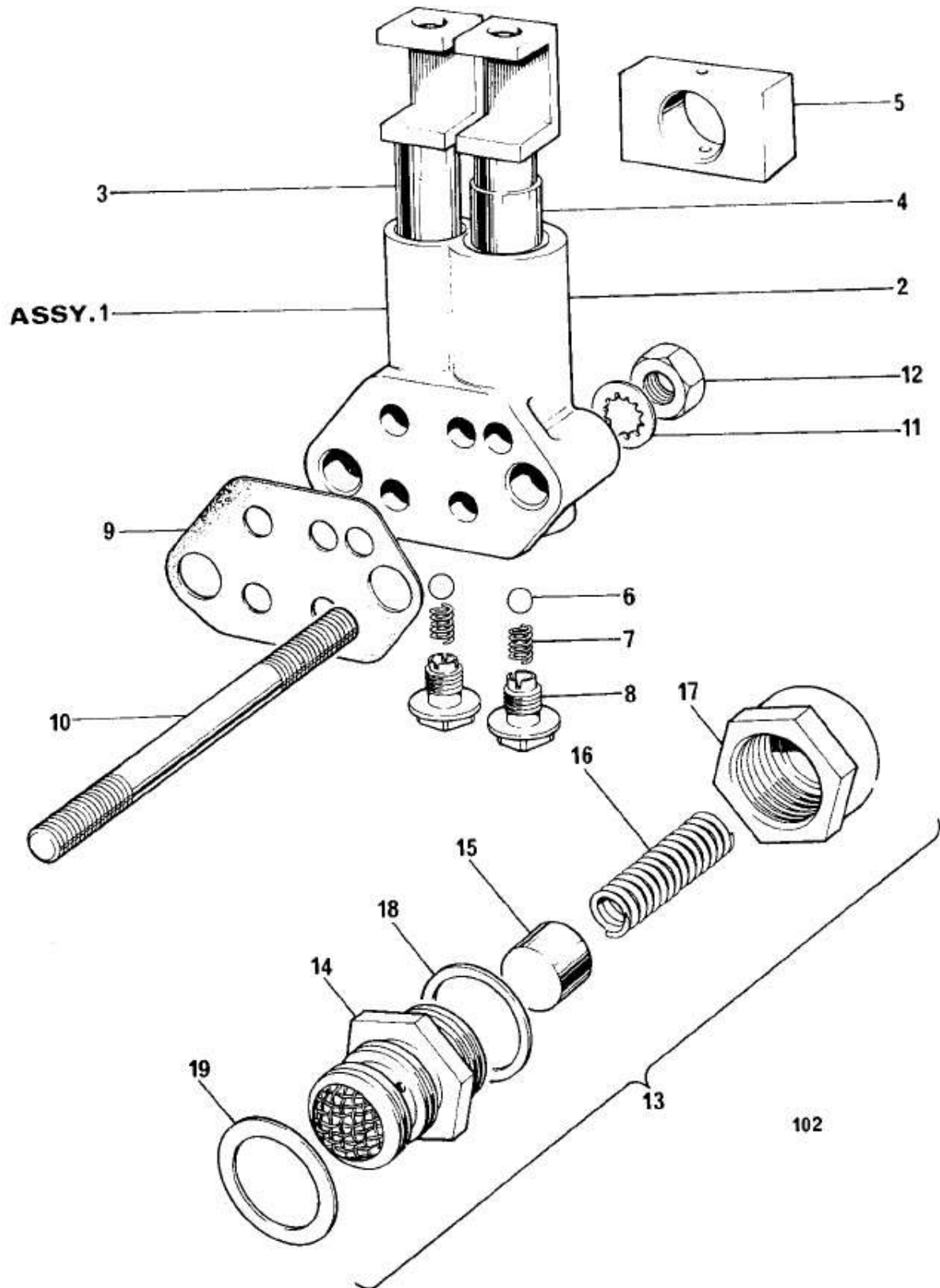

Fig. 3. OIL PUMP AND RELEASE VALVE

OIL PUMP AND RELEASE VALVE

Ref. No.	Part No.	Description	Quantity	Remarks
1	70-9421	OIL PUMP	1	
2	Reference only	Pump body	1	
3	70-9269	Feed plunger	1	
4	70-6681	Scavenger plunger	1	
5	70-0495	Drive block	1	
6	60-2363	Valve ball (7/32 in. dia.)	2	
7	70-0403	Valve spring	2	
8	70-2360	Screwed plug	2	
9	71-3910	Joint washer	1	
10	21-1864	Oil pump stud	2	
11	70-3887	Serrated washer	2	
12	21-1906	Nut	2	
13	71-3447	OIL PRESSURE RELEASE VALVE	1	
14	70-7590	Body	Reference only	
15	70-8752	Piston	Reference only	
16	70-7591	Spring	Reference only	
17	70-6596	Cap	Reference only	
18	70-8754	Joint washer (cap to body)	1	
19	60-3355	'O' ring, release valve to crankcas :	1	

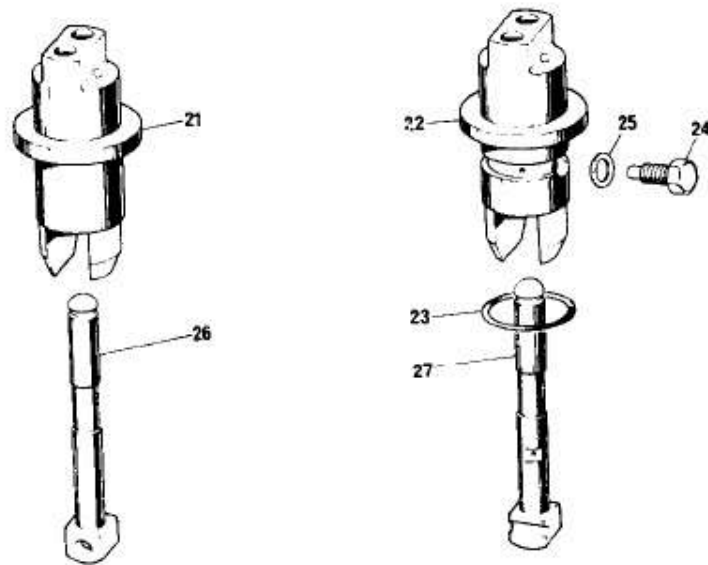
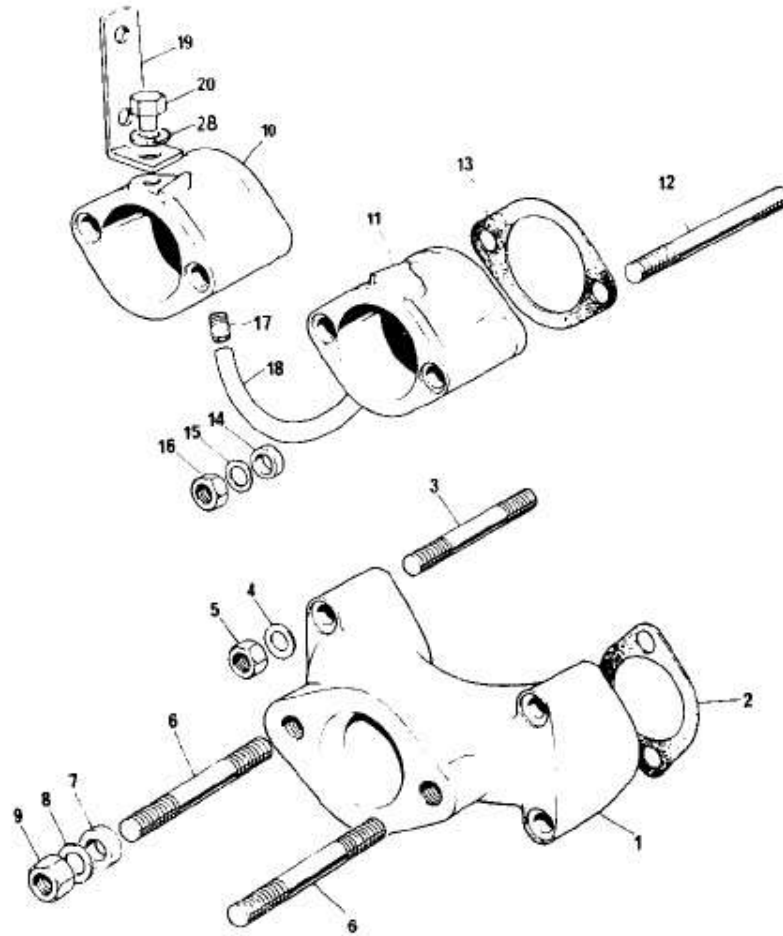

Fig. 4. MANIFOLD AND TAPPETS

MANIFOLD AND TAPPETS

Ref. No.	Part No.	Description	Quantity	Remarks
1	71-3556	Inlet manifold	1	TR7RV
2	70-5660	Joint washer	2	
3	21-1876	Stud	4	
4	60-4248	Washer Manifold to head	4	
5	21-1877	Nut	4	
6	21-1996	Stud	2	
7	70-9554	Insulating ring	2	
8	70-9555	Cup	2	
9	14-1301	Nut	2	
10	71-3339	Inlet manifold - L.H.	1	T140V
11	71-3338	Inlet manifold - R.H.	1	
12	71-2813	Stud	4	
13	71-3573	Joint washer	2	
14	70-9554	Insulating ring	4	
15	70-9555	Cup	4	
16	14-1301	Nut	4	
17	71-3313	Connector	2	
18	71-3577	Connector pipe	1	
19	83-4898	Bracket - Air control lever	1	
20	14-6113	Screw, bracket to manifold	1	
21	70-9352	Inlet tappet guide block	1	
22	70-9353	Exhaust tappet guide block	1	
23	70-7563	'O' ring	2	
24	97-0200	Set bolt	2	
25	70-2441	Washer	2	
26	71-7008	Inlet tappet	2	
27	70-8801	Exhaust tappet	2	
28	60-4260	Spring, washer	1	

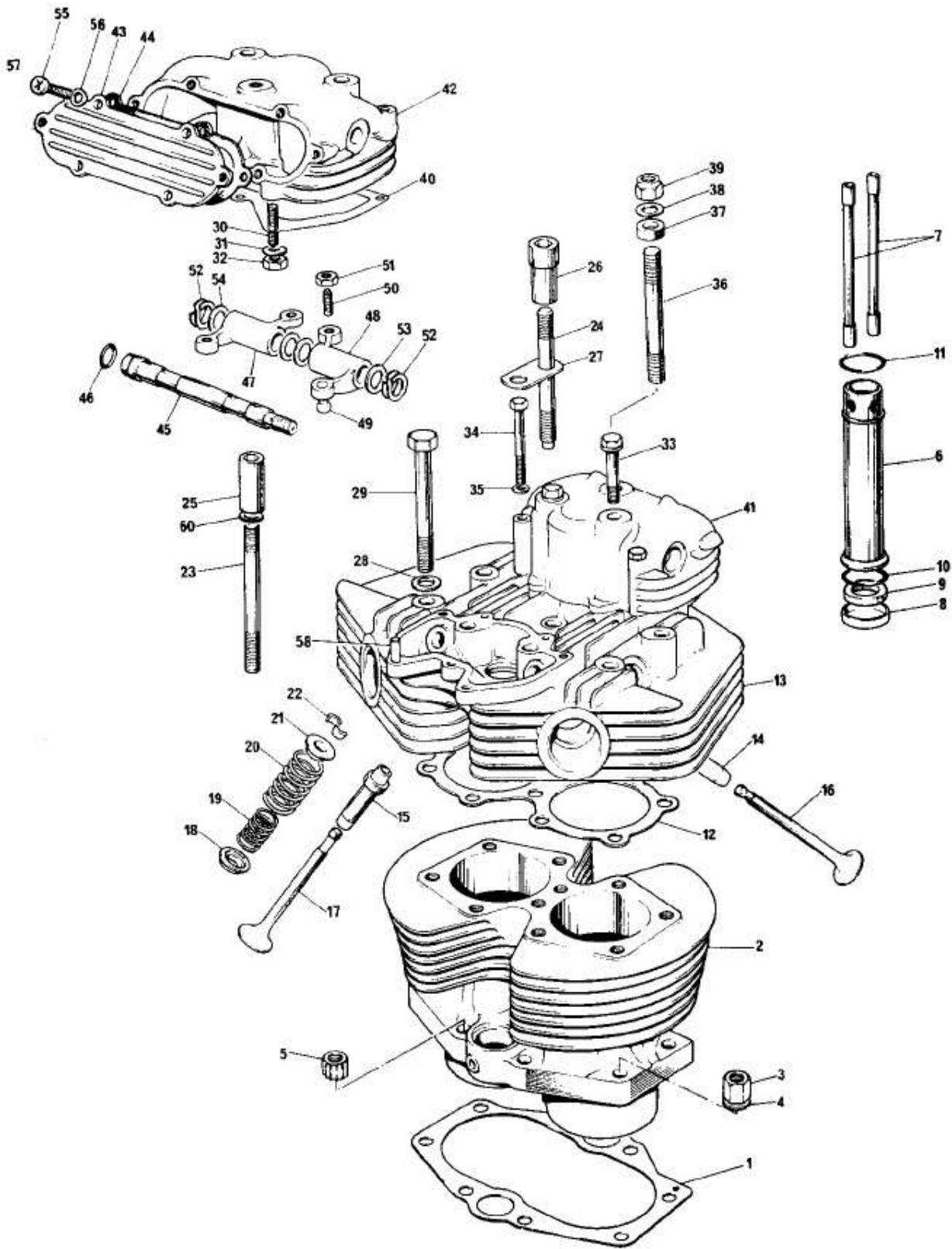

Fig. 5. CYLINDER BLOCK AND HEAD, TR7RV

CYLINDER BLOCK AND HEAD TR7RV

Ref.No.	Part No.	Description	Quantity	Remarks
1	70-6309	Cylinder base washer	1	
2	71-4005	Cylinder block	1	
3	21-2177	Cylinder base nut	4	
4	70-3446	Washer	4	
5	21-0692	Cylinder base nut (12 point)	4	
6	71-3329	Push rod cover tube	2	
7	71-3330	Push rod	4	
8	71-1707	Sleeve	2	
9	70-4752	Sealing ring	2	} Cover tubes
10	70-7310	'O' ring - bottom	2	
11	71-1283	'O' ring - top	2	
12	71-4619	Cylinder head gasket	1	
13	71-4020	CYLINDER HEAD	1	
14	71-3294	Inlet valve guide	2	
15	71-3295	Exhaust valve guide	2	
16	70-4603	Inlet valve	2	
17	70-2904	Exhaust valve	2	
18	71-3296	Bottom cup	4	
19	70-4221	Inner valve spring	4	
20	70-7400	Outer valve spring	4	
21	70-1543	Top collar	4	
22	71-3748	Split cotter	8	
23	21-2201	Stud - cylinder head (3/8 in.)	4	
24	21-2200	Stud - cylinder head (5/16 in.)	2	
25	21-2204	Socket nut (3/8 in.)	4	
26	21-2205	Socket nut (5/16 in.)	2	
27	71-3553	Bridge plate	1	
28	82-2184	Washer	4	
29	14-0241	Bolt - cylinder head	4	
30	14-1401	Stud - rocker box	6	
31	70-3302	Washer	6	
32	14-0301	Nut	6	
33	21-2206	Bolt - rocker box	4	
34	21-1875	Bolt - rocker box	4	
35	60-4248	Washer	4	
36	21-2197	Stud	2	} Torque stay
37	37-2338	Distance piece	2	
38	60-2331	Washer	2	
39	14-1303	Nut	2	
40	71-2599	Rocker box gasket	2	
41	71-3668	Inlet rocker box	1	
42	71-3669	Exhaust rocker box	1	
43	71-3671	Tappet inspection cover	2	
44	71-3673	Gasket	2	
45	71-3549	Rocker spindle	2	
46	60-3548	Sealing ring	2	

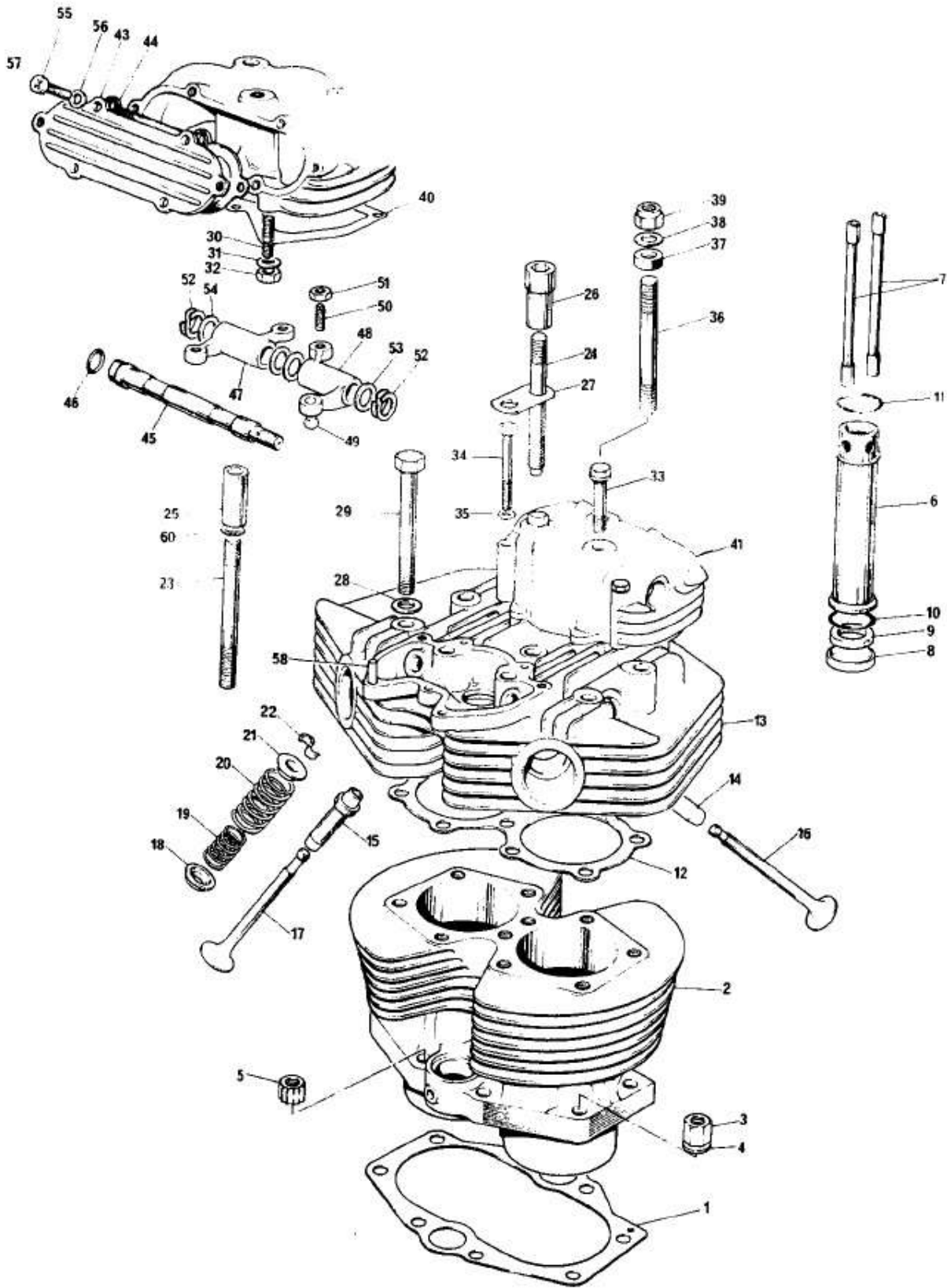
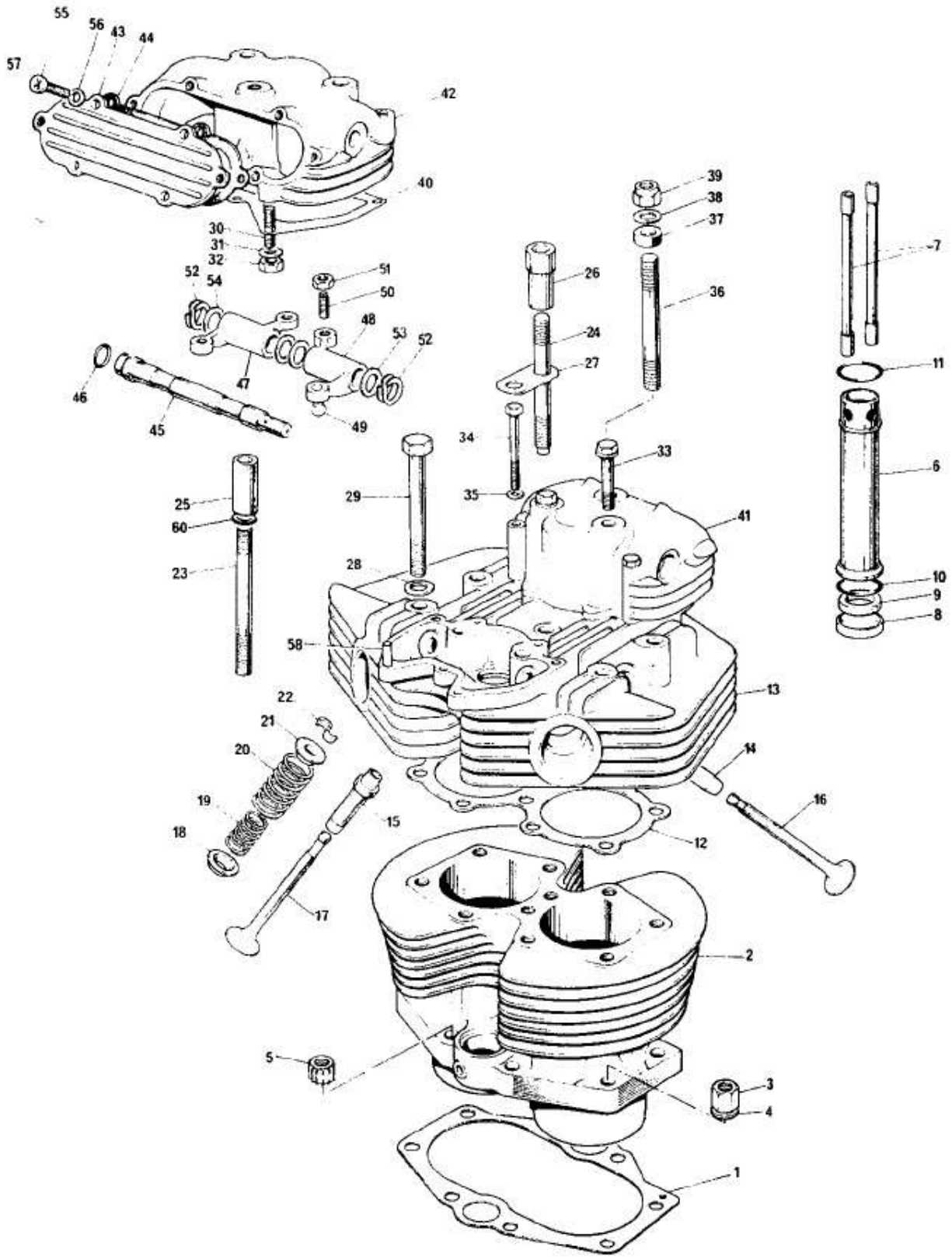

Fig. 5. CYLINDER BLOCK AND HEAD, TR7RV

CYLINDER BLOCK AND HEAD, TR7RV (continued)

Ref. No.	Part No.	Description	Quantity	Remarks
47	70-1457	Rocker (right exhaust, left inlet)	2	Use up to Engine No.
48	70-1458	Rocker (left exhaust, right inlet)	2	
49	71-0070	Ball pin	4	02689. CEI Thread
50	70-1513	Adjusting pin	4	
51	70-0470	Lock nut	4	Use from Engine No. 02690. UNF Thread
47	71-7044	Rocker (right exhaust, left inlet)	2	
48	71-7043	Rocker (left exhaust, right inlet)	2	
49	71-0070	Ball pin	4	
50	71-7045	Adjuster pin	4	
51	14-0401	Lock nut	4	
52	70-1574	Spring washer	4	
53	70-1575	Thrust washer ($\frac{1}{2}$ in.)	6	
54	70-1330	Thrust washer ($\frac{3}{8}$ in.)	2	
55	14-6103	Set screw	8	
56	60-3963	Washer	12	
57	14-6606	Set screw	4	
58	71-2361	Dowel, rocker box to head	4	
60	71-2598	Plain washer	4	



CYLINDER BLOCK & HEAD, T140V

CYLINDER BLOCK AND HEAD, T140V

Ref. No.	Part No.	Description	Quantity	Remarks
1	70-6309	Cylinder base washer	1	
2	71-4005	Cylinder block	1	
3	21-2177	Cylinder base nut	4	
4	70-3446	Washer	4	
5	21-0692	Cylinder base nut (12 point)	4	
6	71-3329	Push rod cover tube	2	
7	71-3330	Push rod	4	
8	71-1707	Sleeve	2	
9	70-4752	Sealing ring	2	} Cover tubes
10	70-7310	'O' ring - bottom	2	
11	71-1283	'O' ring - top	2	
12	71-4619	Cylinder head gasket	1	
13	71-7007	CYLINDER HEAD	1	
14	71-3294	Inlet valve guide	2	
15	71-3295	Exhaust valve guide	2	
16	70-4603	Inlet valve	2	
17	70-2904	Exhaust valve	2	
18	71-3296	Bottom cup	4	
19	70-4221	Inner valve spring	4	
20	70-7400	Outer valve spring	4	
21	70-1543	Top collar	4	
22	71-3748	Split cotter	8	
23	21-2201	Stud - cylinder head (3/8 in.)	4	
24	21-2200	Stud - cylinder head (5/16 in.)	2	
25	21-2204	Socket nut (3/8 in.)	4	
26	21-2205	Socket nut (5/16 in.)	2	
27	71-3553	Bridge plate	1	
28	82-2184	Washer	4	
29	14-0241	Bolt - cylinder head	4	
30	14-1401	Stud - rocker box	6	
31	70-3302	Washer	6	
32	14-0301	Nut	6	
33	21-2206	Bolt - rocker box	4	
34	21-1875	Bolt - rocker box	4	
35	60-4248	Washer	4	
36	21-2197	Stud	2	
37	37-2338	Distance piece	2	} Torque stay
38	60-2331	Washer	2	
39	14-1303	Nut	2	
40	71-2599	Rocker box gasket	2	
41	71-3668	Inlet rocker box	1	
42	71-3669	Exhaust rocker box	1	
43	71-3671	Tappet inspection cover	2	
44	71-3673	Gasket	2	
45	71-3549	Rocker spindle	2	
46	60-3548	Sealing ring	2	

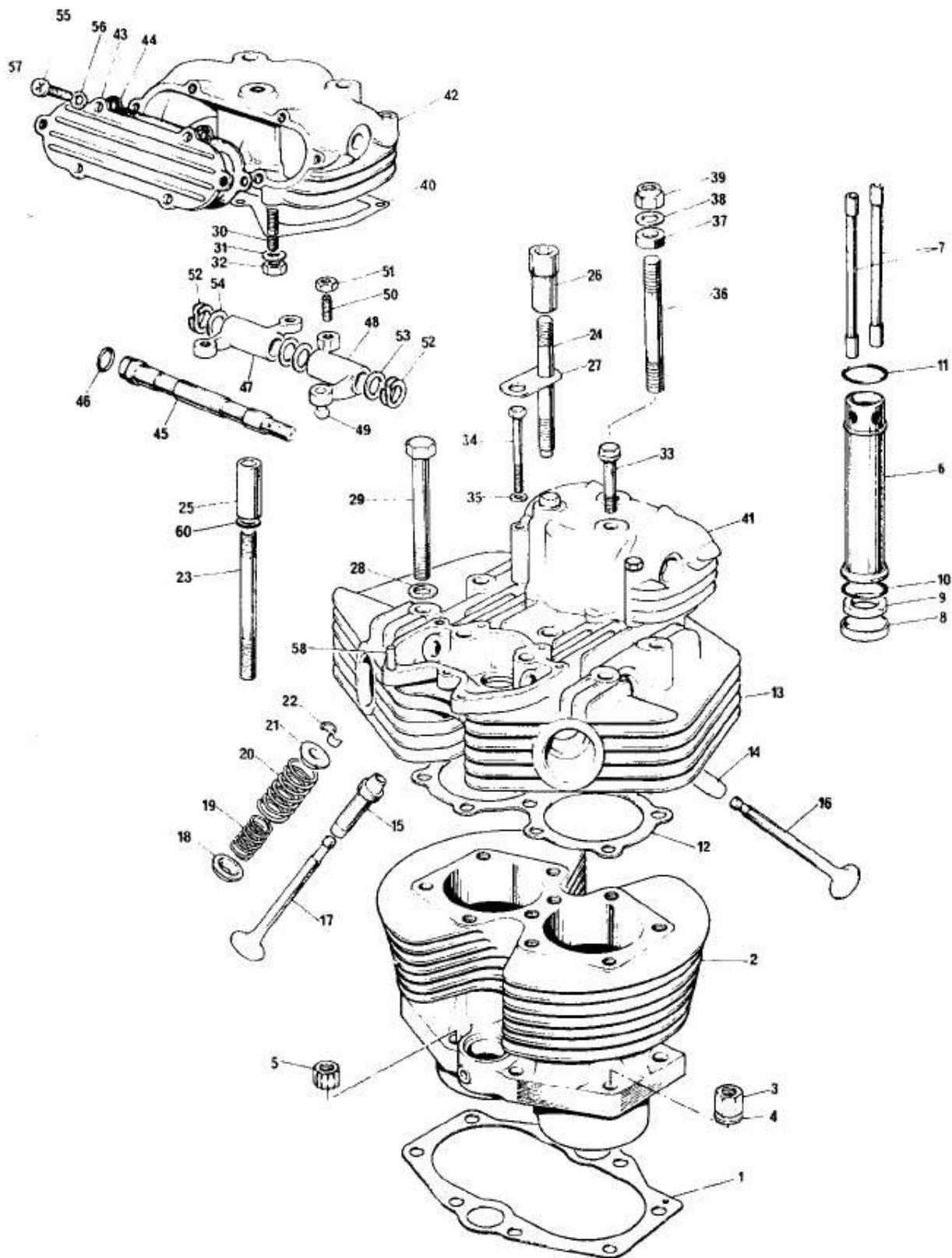

CYLINDER BLOCK & HEAD, T140V

CYLINDER BLOCK AND HEAD, T140V (continued)

Ref No.	Part No.	Description	Quantity	Remarks
47	70-1457	Rocker (right exhaust, left inlet)	2	} Use up to Engine No. 02689. CEI Thread
48	70-1458	Rocker (left exhaust, right inlet)	2	
49	71-0070	Ball pin	4	
50	70-1513	Adjusting pin	4	
51	70-0470	Lock nut	4	
47	71-7044	Rocker (right exhaust, left inlet)	2	} Use from Engine No. 02690. UNF Thread
48	71-7043	Rocker (left exhaust, right inlet)	2	
49	71-0070	Ball pin	4	
50	71-7045	Adjuster pin	4	
51	14-0401	Lock nut	4	
52	70-1574	Spring washer	4	
53	70-1575	Thrust washer ($\frac{1}{2}$ in.)	6	
54	70-1330	Thrust washer ($\frac{3}{8}$ in.)	2	
55	14-6103	Set screw	8	
56	60-3963	Washer	12	
57	14-6606	Set screw	4	
58	71-2361	Dowel, rocker box to head	4	
60	71-2598	Plain washer	4	

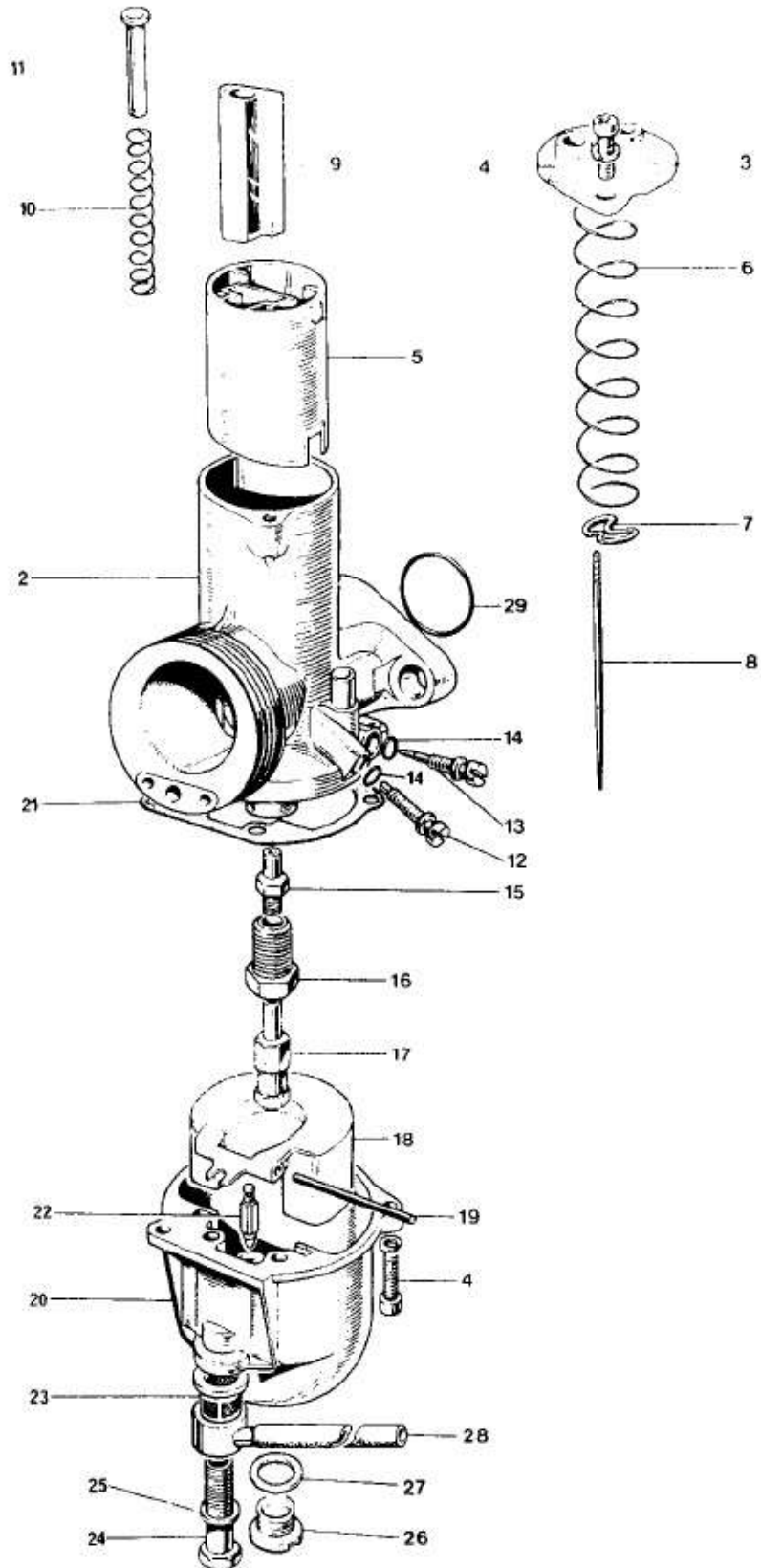

Fig. 8. AMAL CARBURETOR, TR7RV

CARBURETOR TR7RV

Ref. No.	Part No.	Makers Part No.	Description	Quantity	Remarks
1	19-2454	R930/94	CARBURETTOR	1	
2	Amal.	930/005	Carburettor body	1	
3	Amal.	928/098	Mixing chamber top	1	
4	99-0521	622/086	Screw, float and mixing chamber tops	4	
5	99-0527	928/060	Throttle valve (No. 3 cutaway)	1	
6	99-1033	622/131	Throttle return spring	1	
7	99-0510	622/067	Needle clip	1	
8	99-1036	622/124	Needle	1	
9	99-0528	928/062	Air valve	1	
10	99-1038	622/129	Air valve spring	1	
11	99-1037	928/103	Air valve guide	1	
12	99-0516	622/077	Throttle stop screw	1	
13	99-0515	622/076	Pilot air screw	1	
14	99-0520	622/082	'O' ring for air and throttle screws	2	
15	99-1035	622/122	Needle jet (.106)	1	
16	99-1034	622/128	Jet holder	1	
17	99-0454	376/100	Main jet (270)	1	
18	99-0512	622/069	Float	1	
19	99-0513	622/071	Float spindle	1	
20	99-0506	622/055	Float chamber	1	
21	99-0514	622/073	Float chamber washer	1	
22	99-0511	622/068	Float needle	1	
23	99-0438	376/093	Filter	1	
24	99-0517	622/078	Banjo bolt	1	
25	99-1124	13/163	Banjo washer	1	
26	99-1152	622/147	Drain plug	1	
27	99-1153	622/151	Drain plug washer	1	
28	83-4887	-	Petrol pipe	1	
29	70-9711	622/101	'O' ring for flange	1	
	Amal.	622/172	Tickler complete	1	Not illustrated

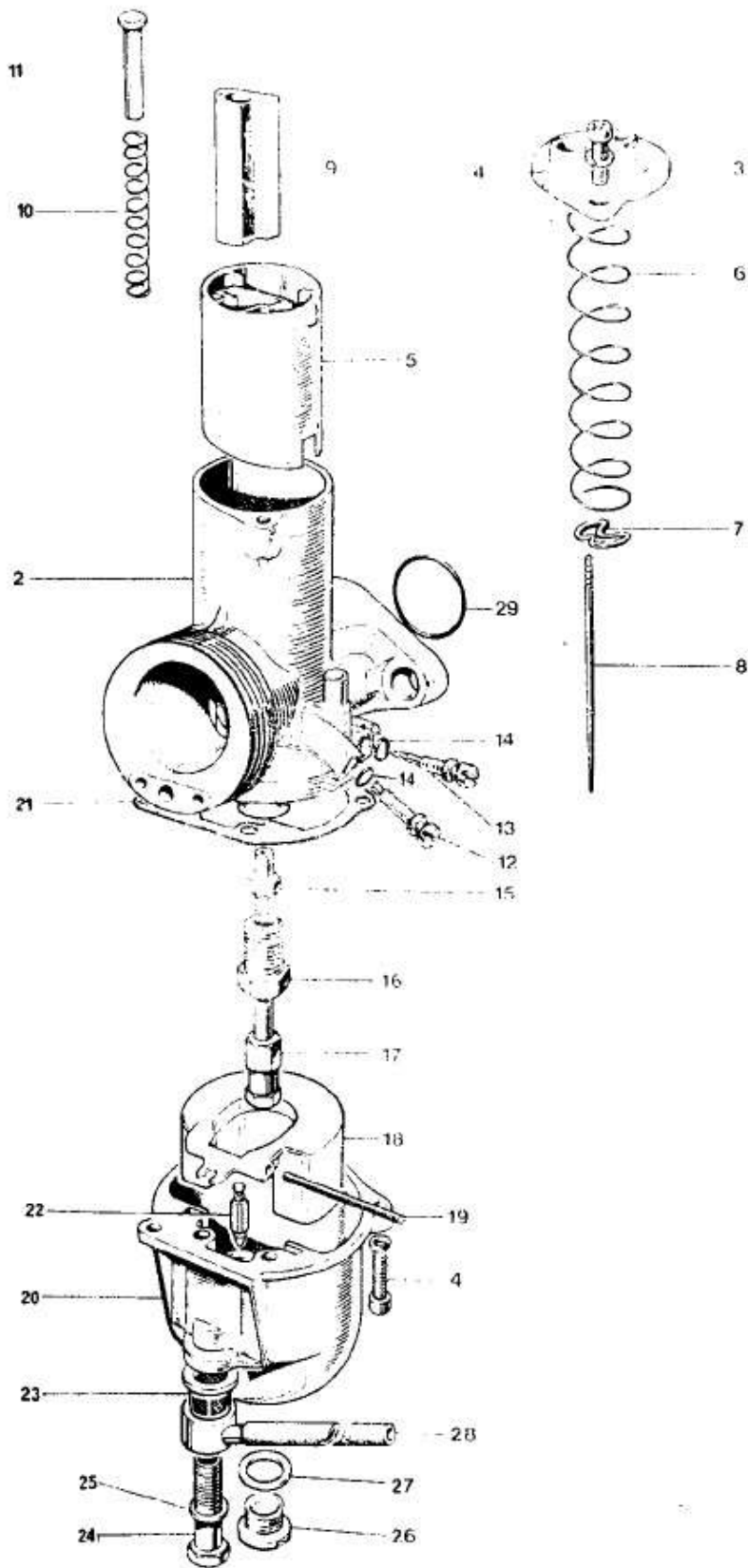

Fig.9. AMAL CARBURETOR, T140V

CARBURETOR T140V

Ref. No.	Part No.	Makers Part No.	Description	Quantity	Remarks
1	19-2452	L930/93	CARBURETTOR, LEFT	1	
1	19-2453	R930/92	CARBURETTOR, RIGHT	1	
2	Amal.	L930	Carburettor body, LEFT	1	
2	Amal	R930	Carburettor body, RIGHT	1	
3	Amal.	928/098	Mixing chamber top	1	
4	99-0521	622/086	Screw, float and mixing chamber tops	4	
5	99-0527	928/060	Throttle valve (No. 3 cutaway)	1	
6	99-1033	622/131	Throttle return spring	1	
7	99-0510	622/067	Needle clip	1	
8	99-1036	622/124	Needle	1	
9	99-0528	928/062	Air valve	1	
10	99-1038	622/129	Air valve spring	1	
11	99-1037	928/103	Air valve guide	1	
12	99-0516	622/077	Throttle stop screw	1	
13	99-0515	622/076	Pilot air screw	1	
14	99-0520	622/082	'O' ring for air and throttle screws	2	
15	99-1035	622/122	Needle jet (.106)	1	Each carburettor
16	99-1034	622/128	Jet holder	1	
17	99-0446	376/100	Main jet (190)	1	
18	99-0512	622/069	Float	1	
19	99-0513	622/070	Float spindle	1	
20	99-0506	622/055	Float chamber	1	
21	99-0514	622/073	Float chamber washer	1	
22	99-0511	622/068	Float needle	1	
23	99-0438	376/093	Filter	1	
24	99-0517	622/078	Banjo bolt	1	
25	99-1124	13/163	Banjo washer	1	
26	99-1152	622/147	Drain plug	1	
27	99-1153	622/151	Drain plug washer	1	
28	82-6209		Petrol pipe Assy	1	T140V
29	70-9711	622/101	'O' ring for flange	1	Each carburettor
	Amal	622/172	Tickler complete	1	Not illustrated

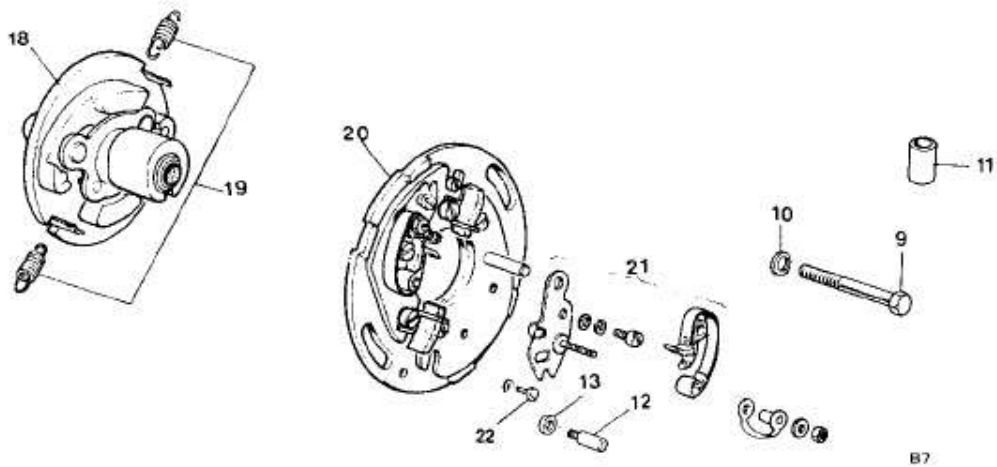
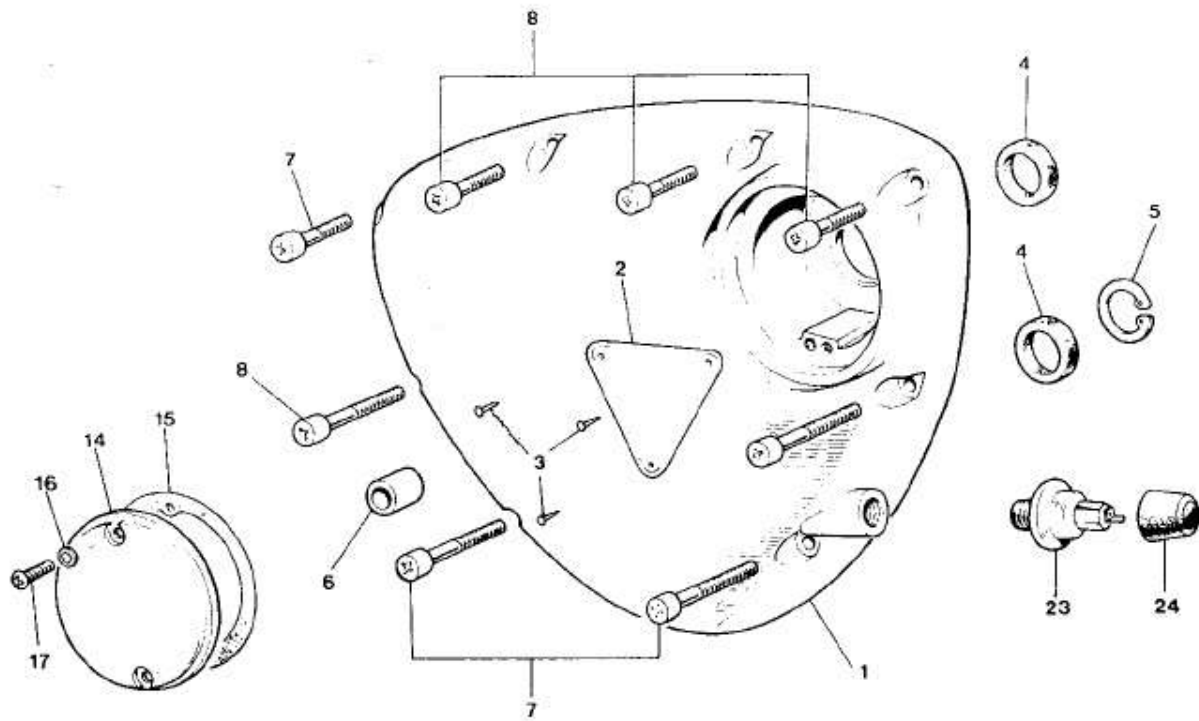

Fig. 10. TIMING COVER AND CONTACT BREAKER

TIMING COVER AND CONTACT BREAKER

Ref. No.	Part No.	Description	Quantity	Remarks
1	71-7042	Timing cover C/W Patent plate	1	
2	70-4016	Patent plate	1	
3	60-4255	Hammer-drive screw	3	
4	70-4568	Oil seal	2	
4	70-6387	Oil seal (0.020 in. undersize)		For reground crankshaft
5	70-4569	Circlip	1	
6	57-0989	Hollow dowel	2	
7	14-6609	Screw, long	2	
8	14-6608	Screw, short	6	
9	14-0208	Bolt	1	
10	70-8163	Plain washer	1	
11	70-4707	Rubber grommet	1	
12	70-7680	Pillar bolt	2	
13	70-6559	Plain washer	2	
14	70-8737	Cover	1	
15	71-1462	Joint washer	1	
16	97-0430	Fibre washer	2	
17	70-7354	Screw ($\frac{1}{2}$ in. U.H.)	2	
18	99-1263	AUTO ADVANCE UNIT	1	Lucas 54425657
19	99-1264	Spring set	1	Lucas 54412229
20	99-1265	CONTACT BREAKER PLATE ASSEMBLY	1	Lucas 54425160
21	99-1266	Contact set	2	Lucas 60600271
22	99-0769	Pin, adjustment	2	Lucas 54419220
23	60-3719	Oil pressure switch	1	
24	71-2930	Cover pressure switch	1	
Not illus.	60-2138	Timing label for C.B. cover	1	

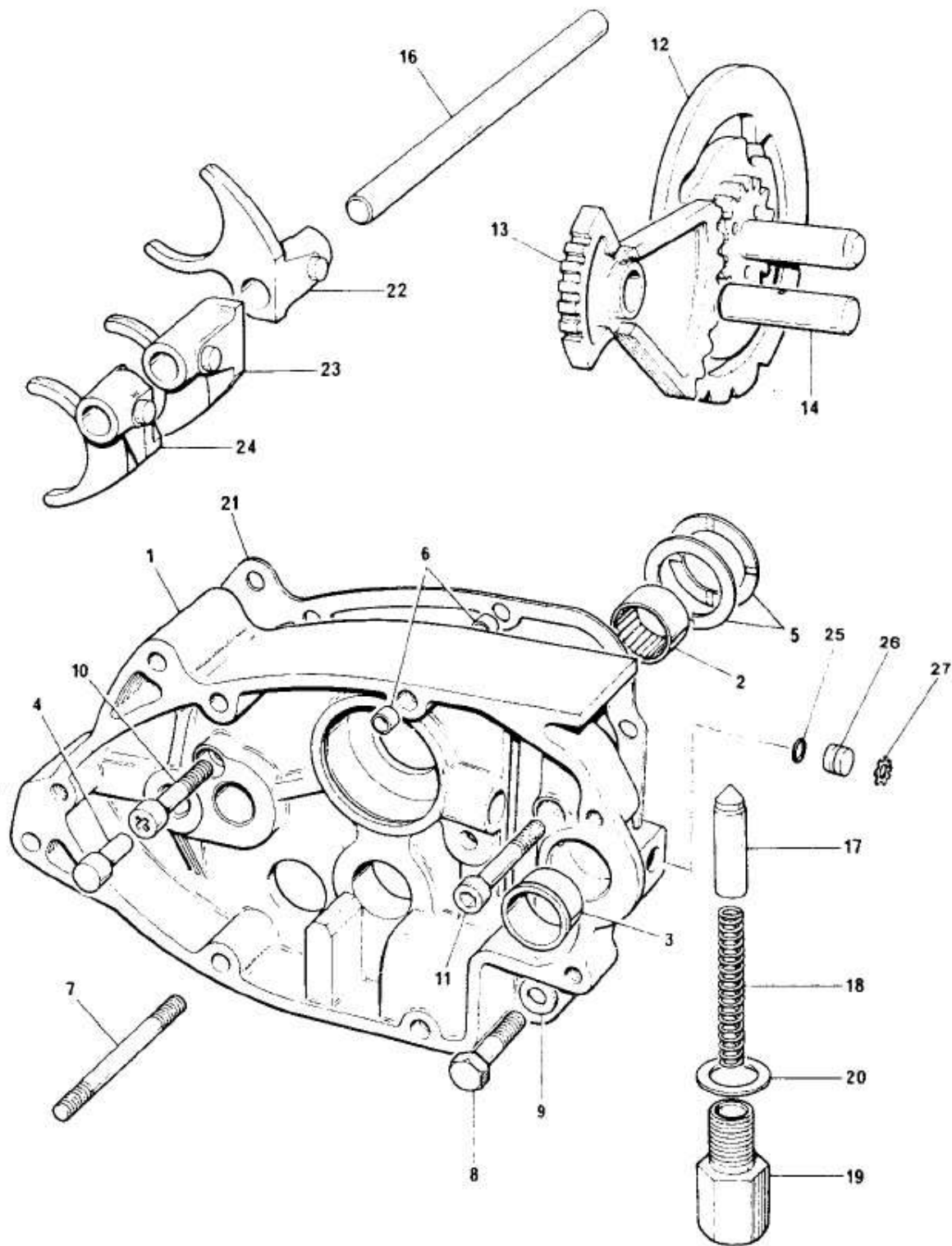

Fig. II GEARBOX INNER COVER AND SELECTORS

GEARBOX INNER COVER AND SELECTORS

Ref. No.	Part No.	Description	Quantity	Remarks
1	57-7001	GEARBOX INNER COVER	1	
2	57-1614	Layshaft bearing	1	
3	57-7009	Gearchange spindle bush	1	
4	57-0045	Kickstart stop	1	
5	57-1607	Thrust washer	2	
6	57-0989	Hollow dowel	4	
7	21-2149	Stud	2	
8	21-1907	Bolt	1	
9	70-3446	Washer	1	
10	14-6608	Screw	1	
11	14-7023	Screw	1	
12	57-4889	Camplate	1	
13	57-7019	Operating quadrant	1	
14	57-7011	Quadrant spindle	1	
16	57-3989	Selector fork rod	1	
17	57-7020	Index plunger	1	
18	57-4459	Plunger spring	1	
19	57-4400	Housing, index plunger	1	
20	57-3978	Washer	1	
21	57-7012	Joint washer, inner cover to crankcase	1	
22	57-4364	Selector fork - mainshaft 4th gear	1	
23	57-4366	Selector fork - layshaft 3rd gear	1	
24	57-4660	Selector fork - layshaft 1st gear	1	
25	37-3761	'O' ring	1	
26	57-7015	Plug	1	
27	57-7016	Retainer	1	

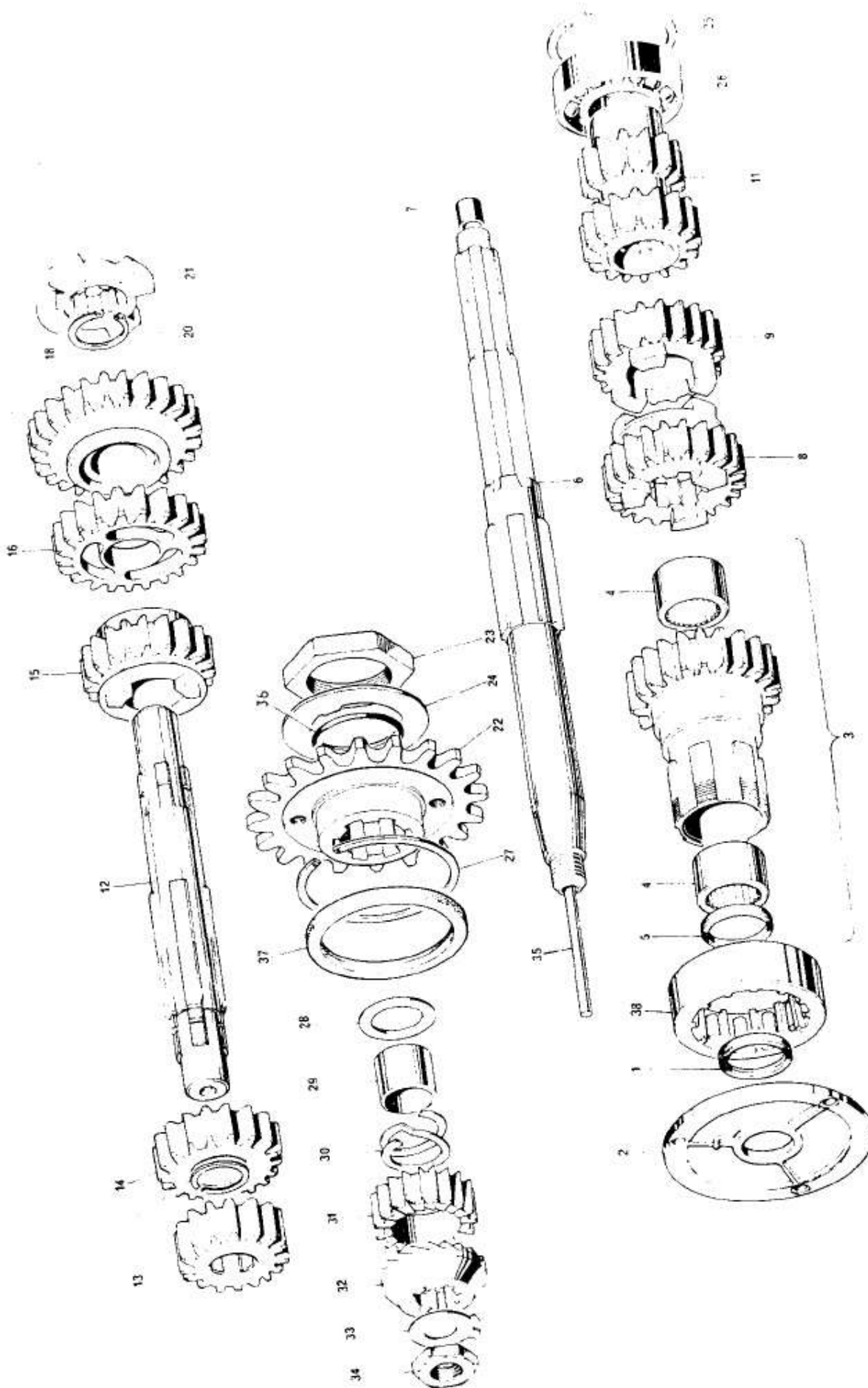

FIG. 12 GEARBOX SHAFTS AND GEARS - 5 SPEED

GEARBOX SHAFTS AND GEARS

Ref. No.	Part No.	Description	Quantity	Remarks
1	60-3500	Oil seal, cover plate	1	
2	70-3789	Cover plate	1	
3	57-4779	MAINSHAFT HIGH GEAR ASSEMBLY	1	
4	60-3511	Needle roller bearing	2	
5	60-3500	Oil seal, high gear	1	
6	57-4432	MAINSHAFT	1	
7	57-3988	Bush	1	
8	57-4376	Mainshaft 4th gear	1	
9	57-4377	MAINSHAFT 3rd GEAR Assy	1	
11	57-4653	Mainshaft 1st and 2nd gear	1	
12	57-4900	LAYSHAFT	1	
13	57-4791	Layshaft high gear		
14	57-4787	Layshaft 4th gear Assy		
	57-4790	Circlip for layshaft high gear		
15	57-4647	Layshaft 3rd gear	1	
16	57-4657	LAYSHAFT 2nd GEAR Assy	1	
18	57-4654	LAYSHAFT 1st GEAR Assy	1	
20	60-3494	Circlip	1	
21	57-4661	Driving dog	1	
22	57-4782	Gearbox sprocket - 20T	1	
23	57-4396	Locknut	1	
24	57-4909	Lock washer	1	
25	70-0489	Circlip	1	
26	60-3552	Mainshaft bearing	1	Hoffman LS8 2 SPOT
27	57-4113	Circlip	1	
28	57-1962	Washer	1	
29	57-1963	Pinion sleeve	1	
30	57-1250	Pinion spring	1	
31	57-0730	Kickstart pinion	1	
32	57-0731	Kickstart ratchet	1	
33	57-2240	Tab washer	1	
34	21-0594	Nut	1	
35	57-1736	Clutch operating rod	1	
36	71-1070	'O' ring, gearbox sprocket	1	
37	60-3512	Oil seal, gearbox sprocket	1	
38	64-4100	High gear bearing	1	

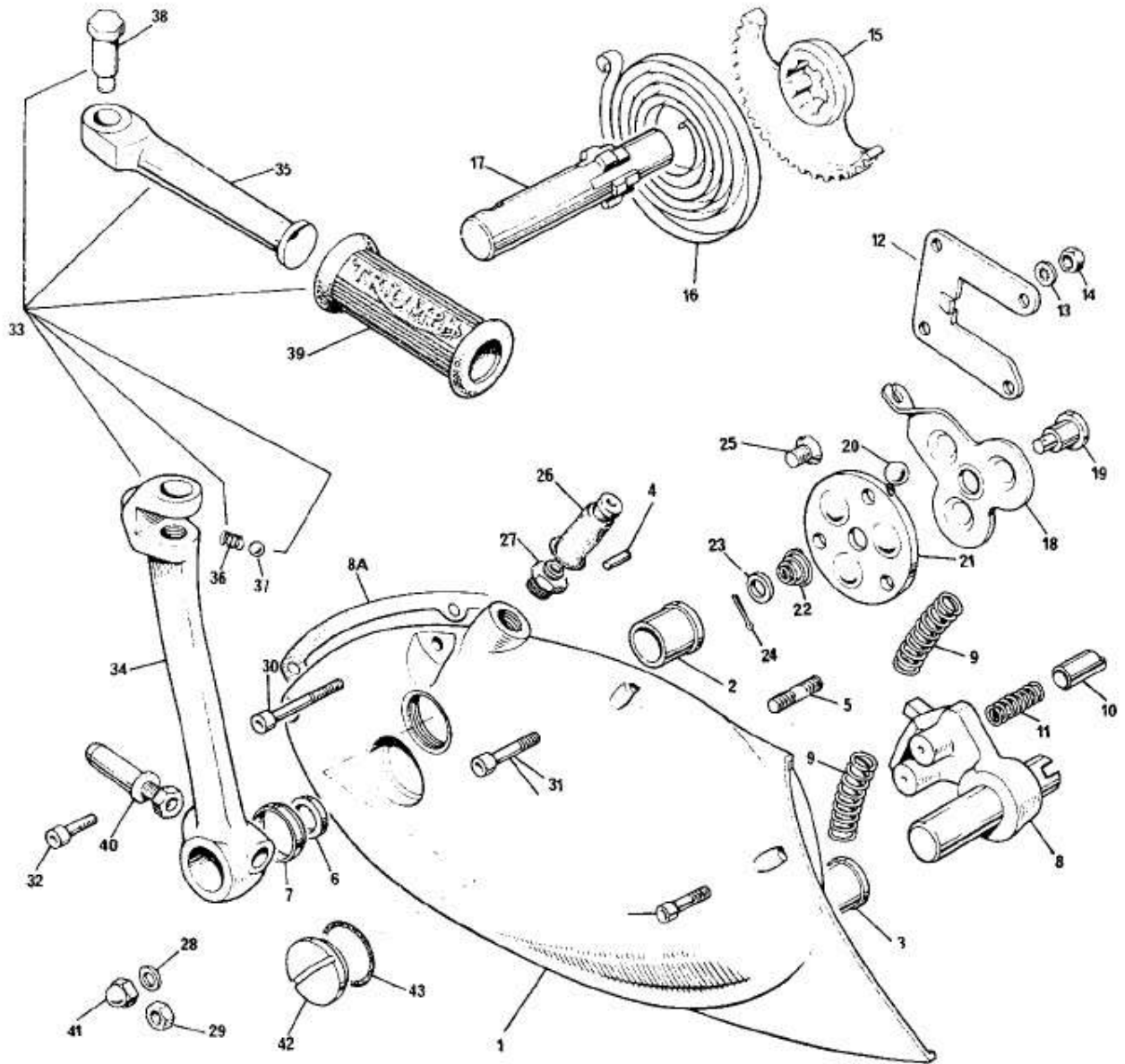

Fig. 13. GEARBOX OUTER COVER

GEARBOX OUTER COVER

Ref. No.	Part No.	Description	Quantity	Remarks
1	57-7014	GEARBOX OUTER COVER	1	
2	57-0023	Kickstarter spindle bush	1	
3	57-7008	Gearchange spindle bush	1	
4	57-0047	Kickstarter spring anchor pin	1	
5	21-0547	Guide plate stud	4	
6	57-1956	Oil seal	1	
7	57-1955	Oil seal housing	1	
8	57-7021	Gearchange quadrant assembly	1	
8A	71-1448	Gasket outer cover	1	
9	57-0404	Quadrant return spring	2	
10	57-4403	Gearchange quadrant plunger	2	
11	57-0405	Plunger spring	2	
12	57-0407	Guide plate	1	
13	70-1612	Serrated washer	4	
14	14-0301	Nut	4	
15	57-4117	Kickstarter quadrant	1	
16	57-0031	Kickstarter return spring	1	
17	57-4756	Kickstarter axle	1	
NOT ILLUSTRATED 57-4587		CLUTCH LEVER ASSEMBLY	1	Items 18 to 24 inclusive
18	57-4588	Clutch lever	1	
19	57-1710	Lever shaft	1	
20	60-2368	Ball, 3/8 in. diam.	3	
21	57-4589	Thrust plate	1	
22	57-1712	Return spring	1	
23	57-3673	Plain washer	1	
24	60-2701	Split pin (5/64 in. x 1/2 in.)	Reference only	
25	21-1879	Countersunk screw	2	
26	57-1646	Rubber cover	1	
27	57-3762	Abutment for clutch cable	1	
28	60-4247	Plain washer	2	
29	14-1302	Nut	1	
30	21-2162	Screw	2	
31	14-6609	Screw	2	
32	14-6608	Screw	1	
33		57-7018	FOLDING KICKSTARTER ASSEMBLY	1
34	57-2173	Kickstarter crank	1	
35	57-7017	Kickstarter pedal	1	
36	57-1167	Pedal locating spring	1	
37	60-2364	Steel ball, 1/4 in. diam.	1	
38	21-0541	Pedal bolt	1	
39	57-2330	Pedal rubber	1	
40	57-4356	Cotter pin c/w nut and washer	1	
41	21-0544	Domed nut	1	
42	57-2166	Filler plug	1	
43	70-8782	'O' ring	1	

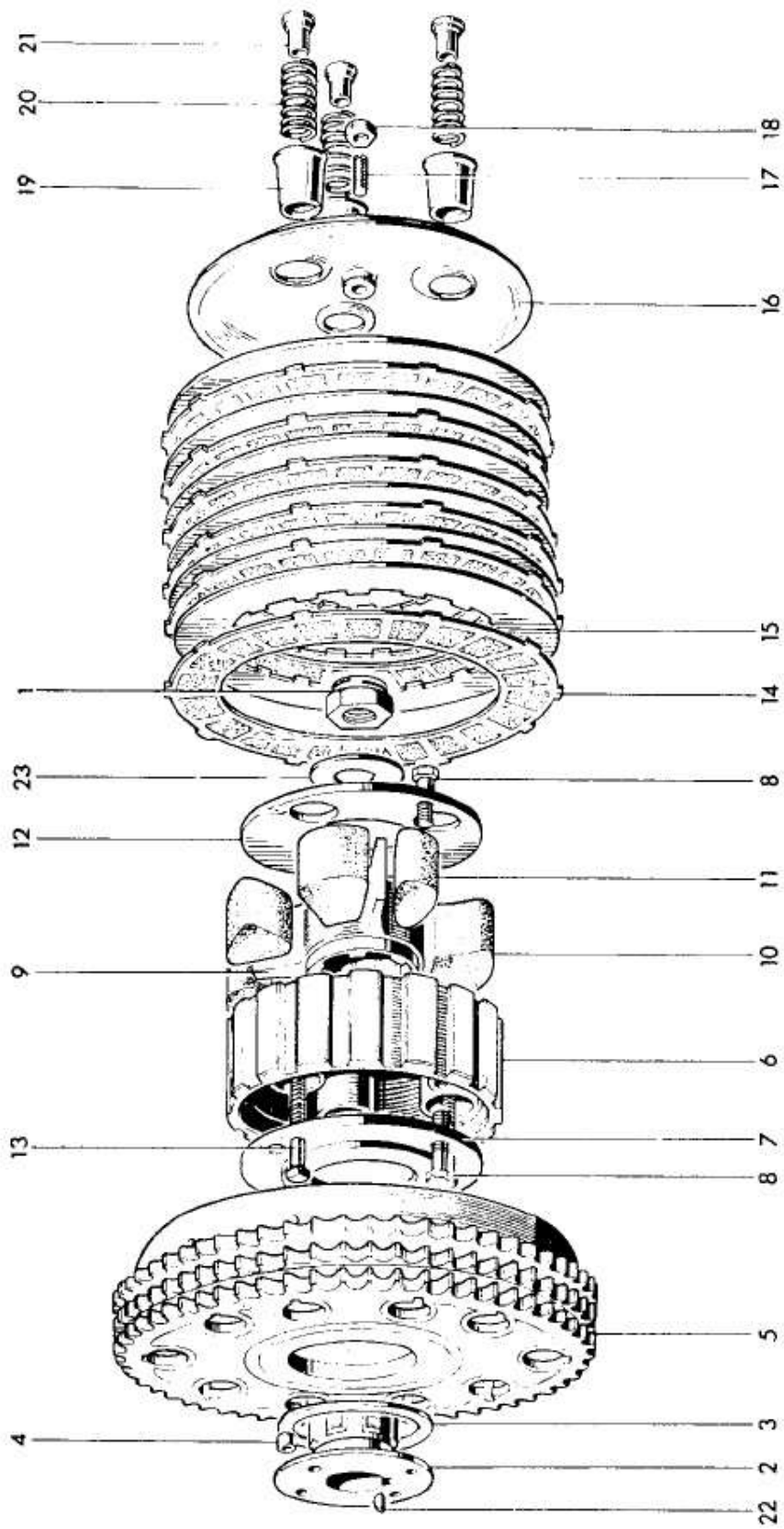

Fig. 14. CLUTCH

CLUTCH

Ref. No.	Part No.	Description	Quantity	Remarks
1	21-0586	Clutch securing nut	1	
2	57-3929	Hub	1	
3	57-3931	Thrust washer	1	
4	57-0394	Roller	2)	
5	57-4640	Sprocket and housing	1	
6	57-4438	Centre	1	
7	57-4436	Inner plate	1	
8	21-2157	Bolt	3	
9	57-4636	Shock absorber spider	1	
10	57-1722	Drive rubber (large)	3	
11	57-1723	Rebound rubber (small)	3	
12	57-4437	Outer plate	1	
13	57-4754	Screwed pin	3	
14	57-4763	Driving plate (bonded)	6	
15	57-1363	Driven plate	6	
16	57-4590	Pressure plate	1	
17	57-2159	Adjuster pin	1	
18	14-0403	Nut	1	
19	57-1931	Spring cup	3	
20	57-4644	Spring	3	
21	57-2526	Pressure nut	3	
22	60-4253	Key	1	
23	57-4794	Washer	1	
Not illustrated	57-4903	Clutch assembly complete	1	
Not illustrated	57-4435	Clutch shock absorber assembly complete	1	

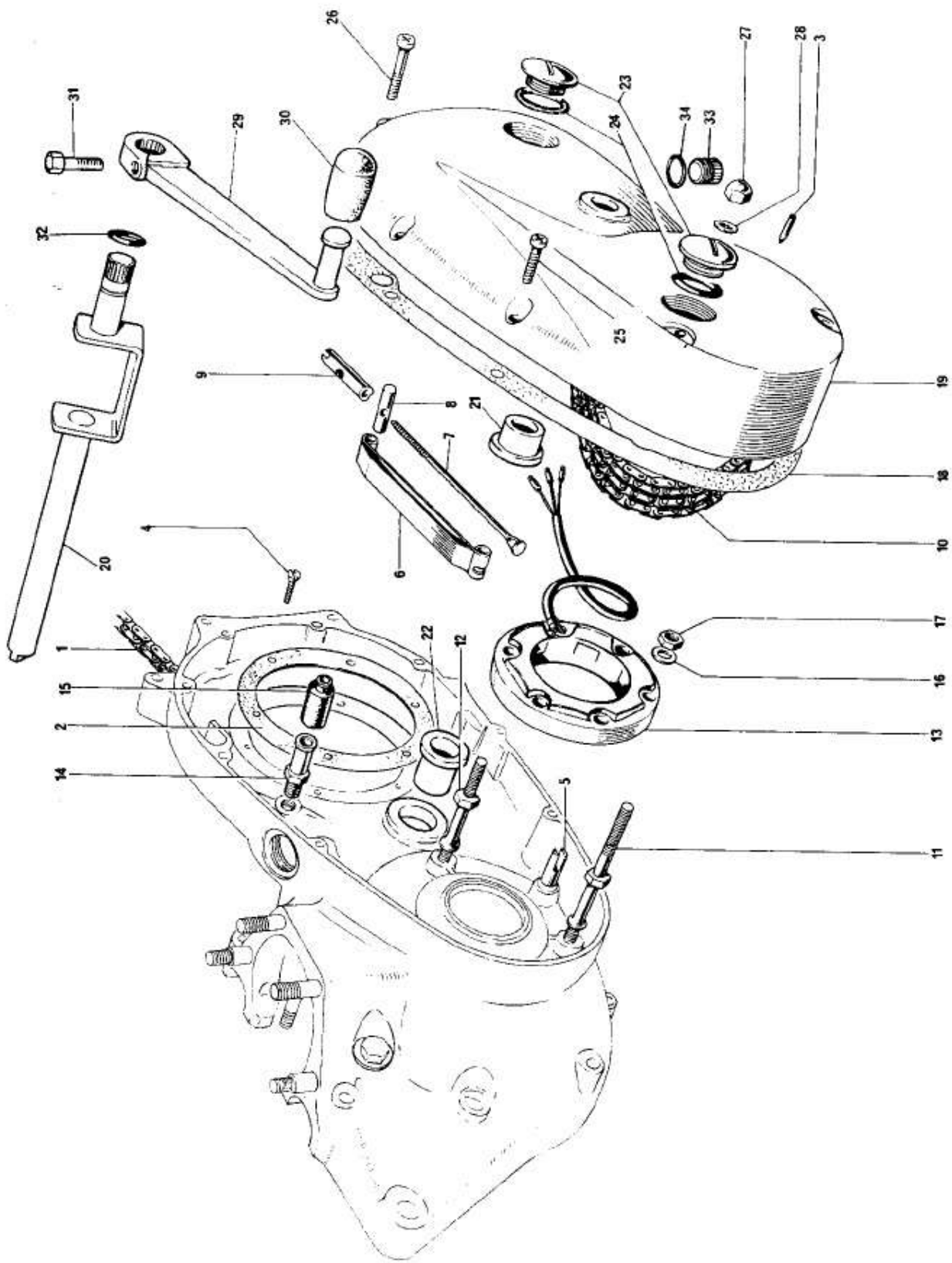

Fig. 15. CHAINCASE AND CHAINS

CHAINCASE AND CHAINS

Ref. No.	Part No.	Description	Quantity	Remarks
1	60-2118	Rear chain, 5/8 in. x 3/8 in. x 107 links	1	
2	71-1419	Joint washer	1	
3	71-3892	Timing pointer	1	
4	70-3821	Countersunk screw	6	
5	70-5088	Chain tensioner abutment	1	(also listed with crankcase group)
6	70-5085	Chain tensioner blade	1	
7	70-4152	Tie rod	1	
8	70-5087	Trunnion	1	
9	70-9703	Adjuster sleeve nut	1	
10	60-4125	Primary chain, 3/8 in. Triplex x 84 links	1	
11	21-2199	Stator stud	2	
12	21-2198	Stator stud	1	
13	99-1006	Stator, RM21	1	Lucas 47205
14	70-9360	Sleeve nut	1	
15	70-4144	Rubber grommet	1	
16	60-4247	Plain washer	3	
17	14-0702	Self-locking nut	3	
18	71-7009	Joint washer	1	
19	71-7003	Chaincase	1	
20	57-7003	Foot change spindle	1	
21	57-0023	Bushing	1	
22	57-7009	Bushing	1	
23	71-3895	Inspection plug	2	
24	71-3896	'O' ring	2	
25	14-6608	Screw	6	
26	14-6620	Screw	2	
27	21-0544	Domed nut	2	
28	82-1880	Copper washer	2	
29	57-7010	Gearchange pedal	1	
30	57-2450	Pedal rubber	1	
31	14-0201	Bolt	1	
32	60-2640	'O' ring shift spindle	1	
33	14-7017	Drain plug - primary cover	1	
34	70-7431	'O' ring - drain plug	1	

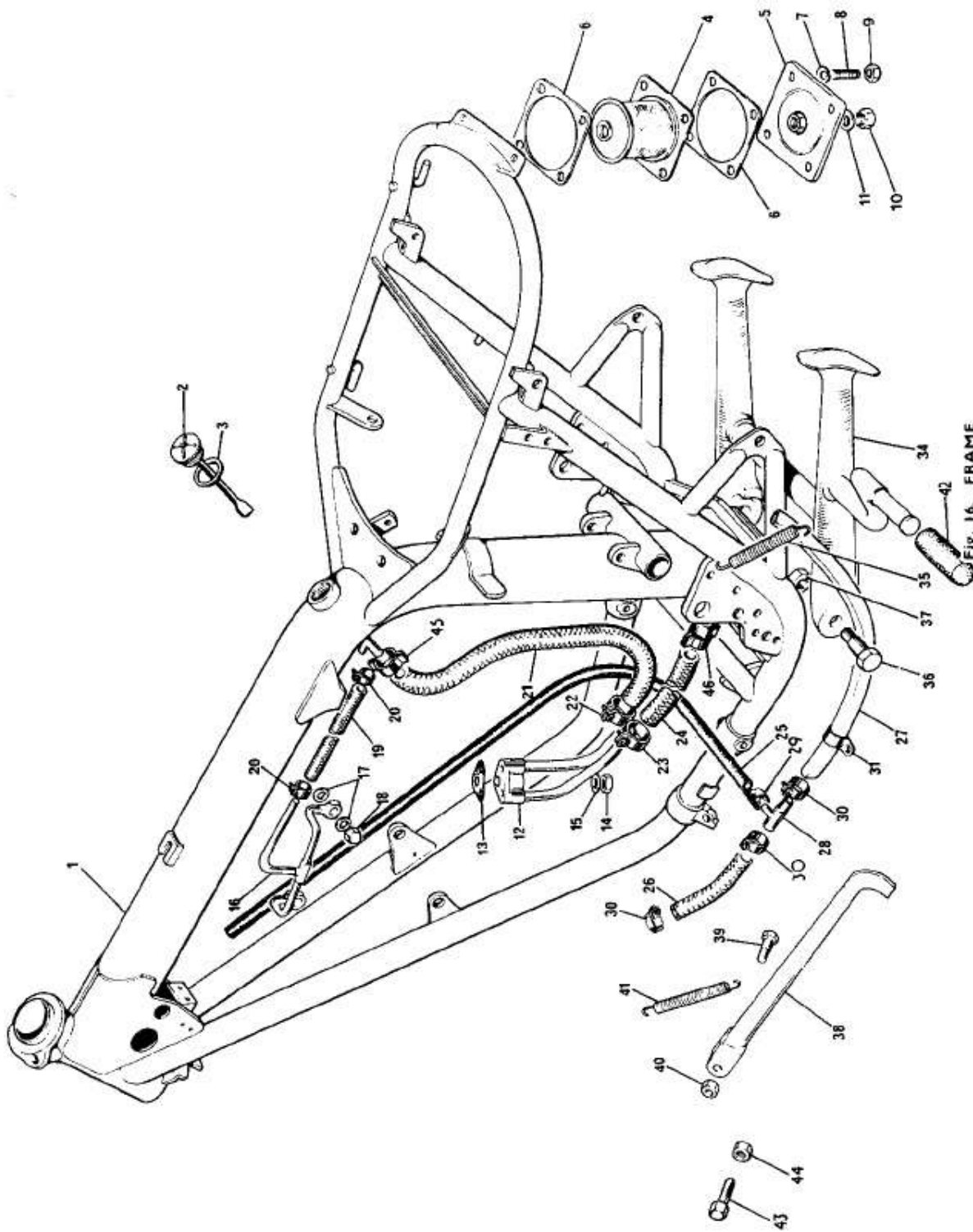

FIG. 16. FRAME

FRAME

Ref. Nr	Part No.	Description	Quantity	Remarks
1	83-7032	Frame	1	
2	71-3463	Oil Filler cap	1	
3	60-3616	'O' ring	1	
4	83-4783	Oil filter	1	
5	71-3316	Sump plate	1	
6	83-2829	Gasket	2	
7	60-2330	Washer	4	} Sump plate to frame
8	21-2109	Stud	4	
9	14-1302	Nut	4	
10	82-5343	Drain plug	1	
11	70-1335	Copper washer	1	
12	71-7013	Oil junction block	1	
13	71-3754	Joint washer	1	
14	21-1908	Nut	1	} Junction block to crankcase
15	70-3446	Washer		
16	71-3550	Rocker oil pipe	1	
17	70-1335	Washer	4	
18	21-0550	Nut	2	
19	71-3551	Rocker feed pipe	1	
20	70-6848	Clip - rocker feed pipe	2	
21	71-7014	Oil return pipe	1	
22	70-6848	Clip - return pipe	1	
23	82-9073	Clip - feed pipe	1	
24	71-7015	Oil feed pipe	1	
25	71-2349	Oil vent pipe	1	
26	83-5285	Crankcase breather pipe - front	1	
27	83-4813	Crankcase breather pipe - rear	1	
28	83-5290	'T' piece	1	
29	83-7069	Clip - vent pipe to 'T' piece	1	
30	60-2252	Clip - breather pipe - front and rear	2	
31	83-1615	Clip - breather pipe to fender	4	
34	83-4941	Centre stand	1	
35	83-3793	Spring	1	
36	21-2077	Pivot bolt	2	
37	14-1304	Nut	2	
38	83-1560	Prop stand	1	
39	82-7021	Bolt	1	
40	14-1303	Nut	1	
41	82-8382	Spring	1	
42	57-2331	Pedal rubber, centre stand	1	
Not illus.	60-3361	Transfer "Made in England"	1	
43	14-0114	Bolt	1	} Prop stand stop
44	14-0402	Nut		
45	60-4428	'Ear' clamp, oil return pipe	1	
46	60-4429	'Ear' clamp, oil feed pipe	1	

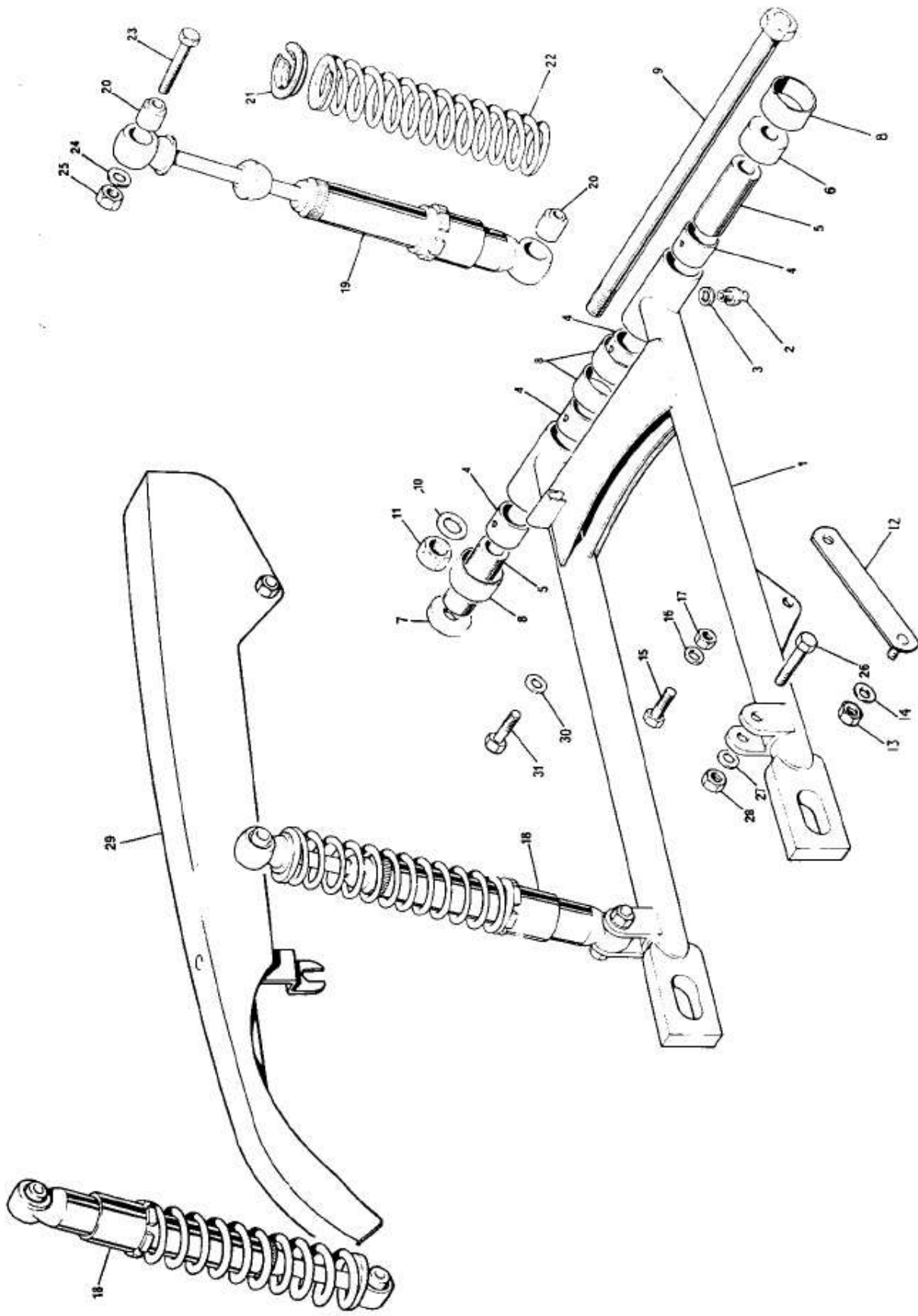

Fig. 17. SWINGING FORK AND SUSPENSION UNITS

SWINGING ARM AND SUSPENSION UNITS

Ref. No.	Part No.	Description	Quantity	Remarks
1	83-7035	SWINGING ARM	1	
2	60-1841	Grease nipple	2	
3	71-2501	Washer, grease nipple	2	
4	83-2521	Bush, pivot arm	4	
5	83-2691	Sleeve, swinging arm pivot	2	
6	83-2690	Distance piece R.H.	1	
7	83-2689	Distance piece L.H.	1	
8	83-2692	Dirt excluder	4	
9	21-2087	Pivot bolt - swinging arm	1	
10	83-2266	Washer, swinging arm pivot	2	
11	14-1307	Nut, swinging arm pivot	1	
12	83-7028	Brake torque stay	1	
13	14-1303	Nut	1	
14	60-4246	Washer	1	
15	21-7004	Bolt, torque stay to swinging arm	1	
16	60-2332	Washer, torque stay to swinging arm	1	
17	14-1304	Nut, torque stay to swinging arm	1	
18	60-3957	SUSPENSION UNIT	Girling 64052564	2
19	Girling	Damper unit	Girling 6405263	
20	99-0122	Bonded bush	Girling 64533645	4
21	99-0107	Spring retainer	Girling 9054/171	4
22	99-1048	Spring, 110 lbs. chrome	Girling 64543708	2
18	60-7037	SUSPENSION UNIT	Girling 70056007	2 USA only
19	Girling	Damper unit	Girling 70056008	2 " "
20	99-7004	Bonded bush	Girling 64541161	4 " "
21	99-7005	Spring retainer	Girling 70520135	2 " "
22	99-1048	Spring chrome 110lbs.	Girling 64543708	2 " "
23	14-0235	Bolt, damper - top		2
24	60-2331	Washer, damper - top		2
25	14-1303	Nut, damper - top		2
26	14-0234	Bolt, damper, lower		2
27	60-2331	Washer damper lower		2
28	14-1303	Nut damper lower		2
29	83-2641	Chainguard		1
30	60-2347	Washer, chainguard fixing - front		1
31	14-0206	Bolt, chainguard fixing front		1

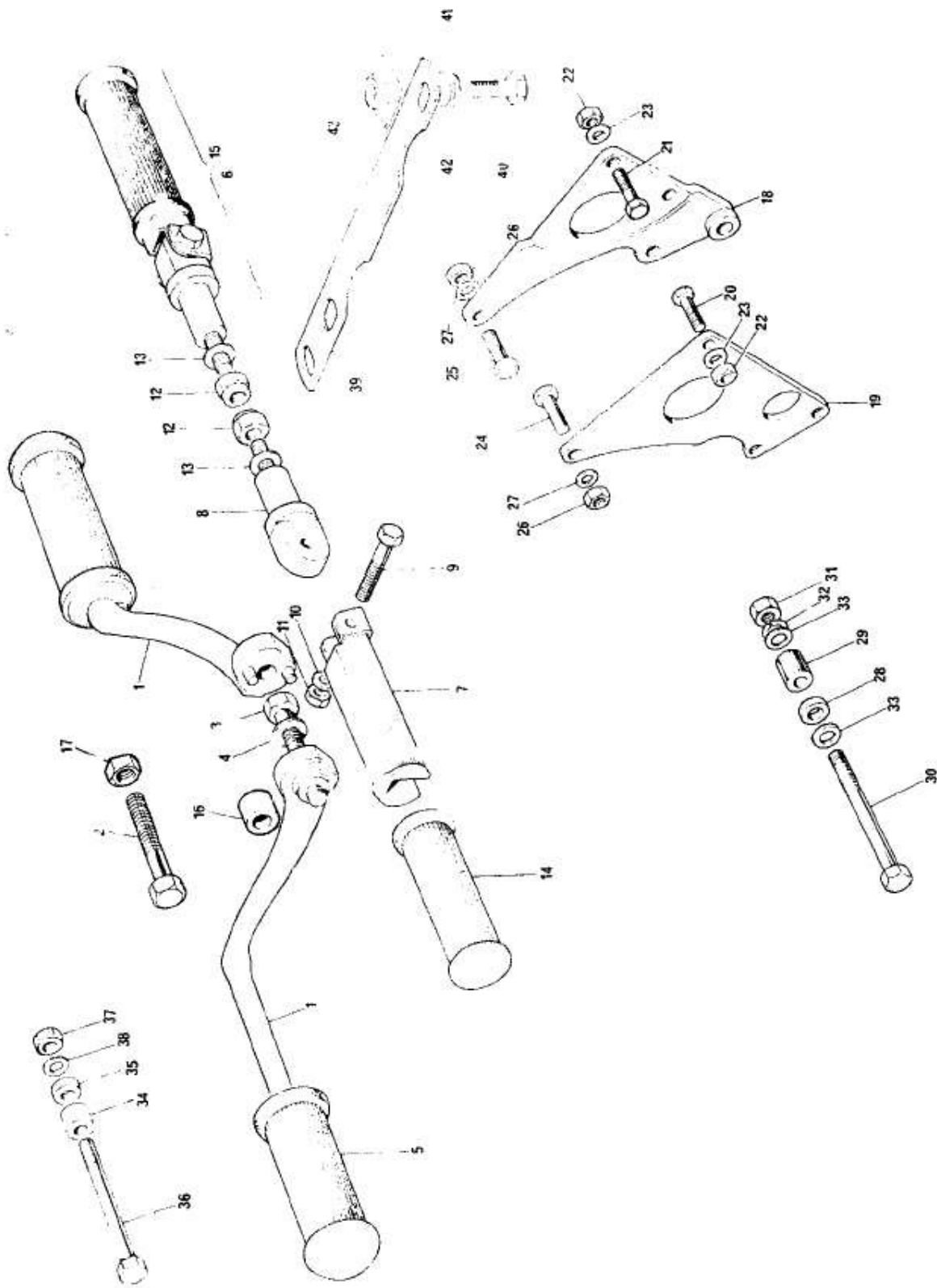

Fig. 18. MOTOR UNIT FITTING AND FOOTRESTS

MOTOR UNIT FITTINGS AND FOOTRESTS

Ref. No.	Part No.	Description	Quantity	Remarks
1	83-7040	Footrest - left and right	2	
2	14-0261	Footrest bolt, right	1	
3	14-0259	Footrest bolt, left	1	
4	60-2333	Washer	2	
5	82-9279	Footrest rubber (alternative 82-9630)	2	
6	83-7026	PILLION FOOTREST ASSEMBLY RIGHT	1	
7	83-7059	Pedal	2	
8	21-7026	Anchor bolt, left	1	
8	21-7027	Anchor bolt, right	1	
9	14-0216	Bolt	2	Footrest swivel
10	82-9089	Washer	2	
11	14-1302	Nut	2	
12	14-1303	Nut	2	Footrest to frame
13	82-2184	Washer	2	
14	82-9054	Footrest rubber	2	
15	83-7025	PILLION FOOTREST ASSEMBLY LEFT	1	
16	83-3602	Distance piece left footrest	1	
17	14-1305	Footrest bolt nut	2	
18	83-7011	Rear motor plate right	1	
19	83-7009	Rear motor plate left	1	
20	14-0115	Bolt	4	Rear motor plates to frame
21	14-0116	Bolt	1	
22	14-1302	Nut	5	
23	60-2330	Washer	9	
24	14-0220	Bolt	2	Motor to motor plates
25	14-0221	Bolt	2	
26	14-1302	Nut	4	
27	60-2321	Washer	8	
28	83-2846	Distance piece - left	1	Motor to frame centre bottom
29	83-2847	Distance piece - right	1	
30	21-2112	Bolt	1	
31	14-0304	Nut	1	Motor fixing front
32	60-4251	Washer	1	
33	60-2332	Washer	1	
34	83-2848	Distance piece - left	1	
35	83-2849	Distance piece - right	1	Motor fixing front
36	14-0254	Bolt	1	
37	14-1304	Nut	1	
38	60-2332	Washer	1	
39	83-3537	Steady bracket motor to frame	1	
40	14-0129	Bolt	1	Bracket to frame
41	83-3329	Distance piece	1	
42	60-2419	Washer	1	
43	83-4086	Attachment plate	1	

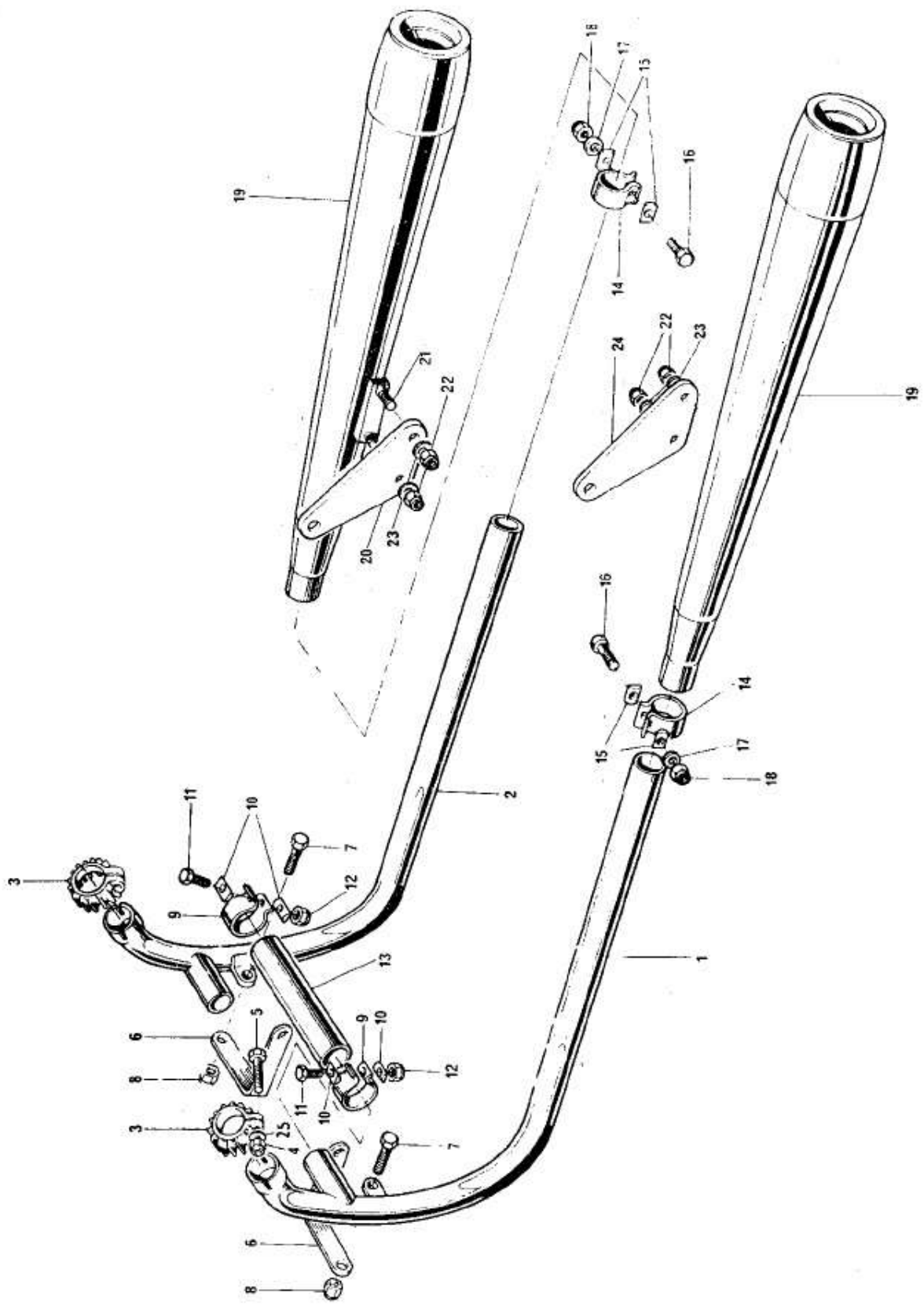
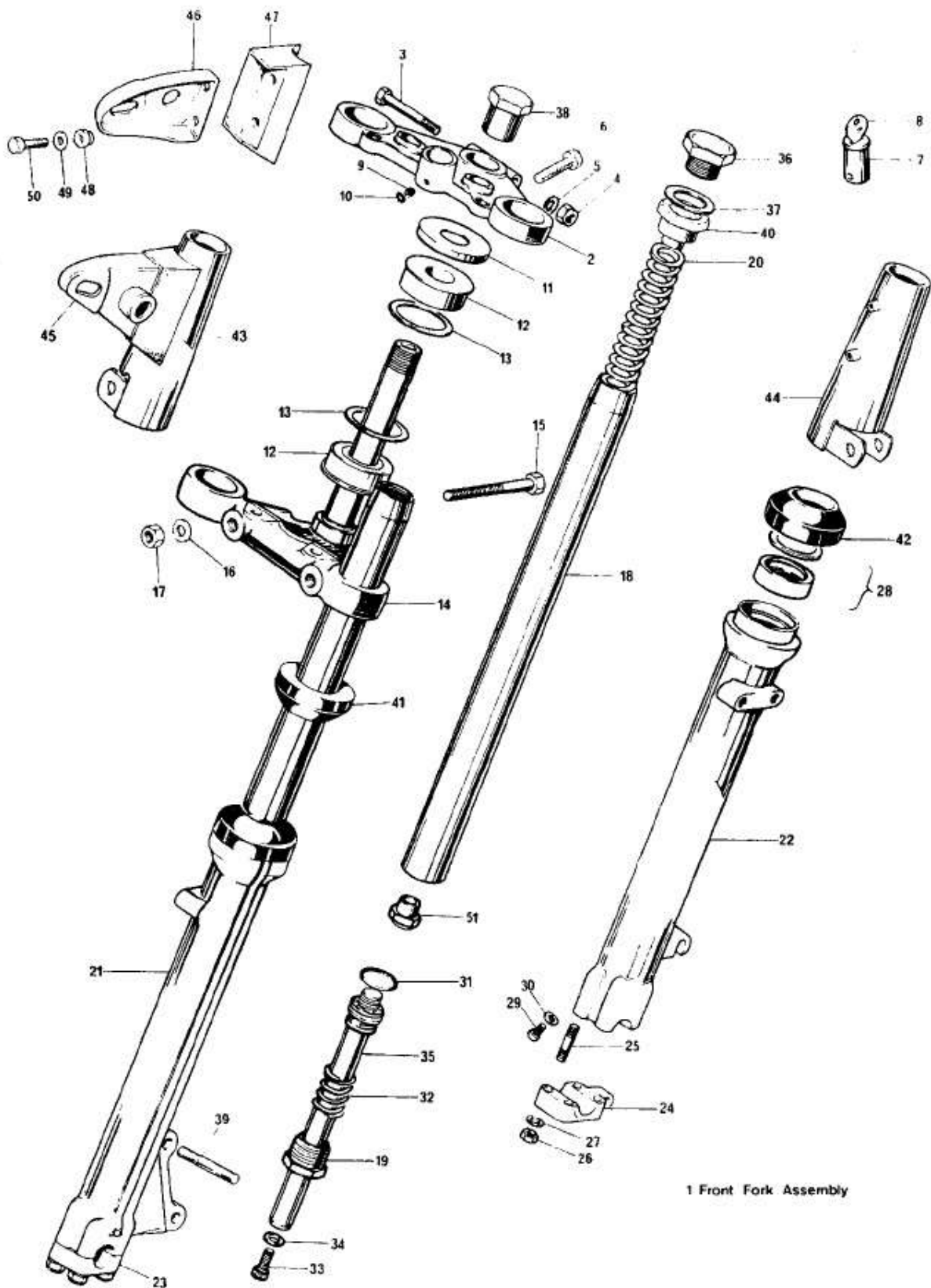

Fig. 19. EXHAUST PIPES AND MUFFLERS

EXHAUST PIPES AND MUFFLERS, TR7RV, T140V

Ref. No.	Part No.	Description	Quantity	Remarks
1	71-3755	Exhaust pipe - left	1	
2	71-3758	Exhaust pipe - right	1	
3	71-2465	Finned clip	2	
4	21-7009	Nut	2	
5	21-2230	Screw	2	
6	70-6857	Exhaust pipe stay	2	
7	14-2205	Screw	2	
8	14-1201	Nut	2	
9	70-7512	Clip	2	
10	70-3768	'D' washer	4	Exhaust pipes to coupling pipe
11	14-0217	Bolt	2	
12	14-1202	Nut	2	
13	70-9888	Coupling pipe	1	
14	70-5874	Clip	2	
15	70-3768	'D' washer	4	Exhaust pipes to mufflers
16	14-0219	Bolt	2	
17	60-4247	Washer	2	
18	14-1202	Nut	2	
19	71-4159	Muffler	2	
20	83-7021	Hanger - muffler right	1	
21	14-0102	Bolt	4	Muffler to hanger
22	14-1201	Nut	4	
23	60-4248	Washer	4	
24	83-7022	Hanger muffler left	1	
25	60-2416	Washer	2	



1 Front Fork Assembly

Fig. 20. TELESCOPIC FRONT FORK

TELESCOPIC FRONT FORK

Ref. No.	Part No.	Description	Quantity	Remarks
1	97-4616	FORK ASSEMBLY	1	General & U.K.
1	97-4396	FORK ASSEMBLY	1	U.S.A.
2	97-4397	Top Yoke See Page 52	1	c/w lock assy.
3	14-0234	Pinch bolt	1	
4	14-1303	Nut	1	
5	60-2331	Washer	1	
6	14-1034	Cap screw	2	
7	82-6738	Lock c/w 2 keys See Page 52	1	
8	60-0623	Key (state serial no.)	1	
9	21-0578	Grub screw	1	
10	97-2266	Sealing washer	1	
11	83-2007	Abutment ring	2	
12	97-4031	Taper roller bearing	2	
13	97-4028	Dust cover	2	
14	97-4385	Bottom yoke and stem	1	
15	14-0237	Pinch bolt, RIGHT	1	
15	97-4476	Eye bolt, LEFT	1	
16	82-2184	Washer	3	
17	14-1303	Nut	2	
18	97-4380	Stanchion	2	
19	97-4076	End plug	2	
20	97-4011	Main spring	2	
21	97-4399	OUTER MEMBER - LEFT	1	
22	97-4579	OUTER MEMBER - RIGHT	1	
23	97-4456	Cap, wheel spindle - left	1	
24	97-4457	Cap, wheel spindle - right	1	
25	21-2102	Stud	8	
26	14-0302	Nut	8	
27	60-2428	Washer	8	
28	*97-7010	Oil seal & retainer	2	
		Oil seal retainer	2	Ref only
29	97-3894	Drain plug	2	
30	97-3893	Washer	2	
31	97-4003	'O' ring	2	
32	97-4009	Recoil spring	2	
33	14-1019	Cap screw	2	
34	97-4004	Cap screw seal	2	
35	97-4325	Damper tube and valve assembly	2	
36	97-4395	Cap screw	2	
37	97-4166	Washer	2	
38	97-4317	Steering stem nut	1	
39	21-2189	Stud, caliper to outer member	2	
40	97-4387	Top nut	2	
41	97-4461	Rubber ring, outer cover	2	
42	97-4002	Scraper sleeve	2	USA

TELESCOPIC FRONT FORK (continued)

Ref. No.	Part No.	Description	Quantity	Remarks
43	97-4480	Outer cover - left	1	
44	97-4481	Outer cover - right	1	
45	97-4121	Headlamp bracket - left	1	
46	97-4203	Headlamp bracket - right	1	
47	97-2208	Rubber mounting	2	
48	97-2209	Rubber buffer	4	
49	97-2210	Backing washer	4	
50	21-2095	Attachment bolt	4	
Not illus.	82-6784	Grommet, throttle cable	1	
51	97-4012	Nut, damper valve	1	
52	97-1510	Gaiter- fork outer cover	2	Not USA
2	99-4470	Top yoke	1	For Nieman lock
7	60-3780	Lock C/W 2 keys	1	Nieman type

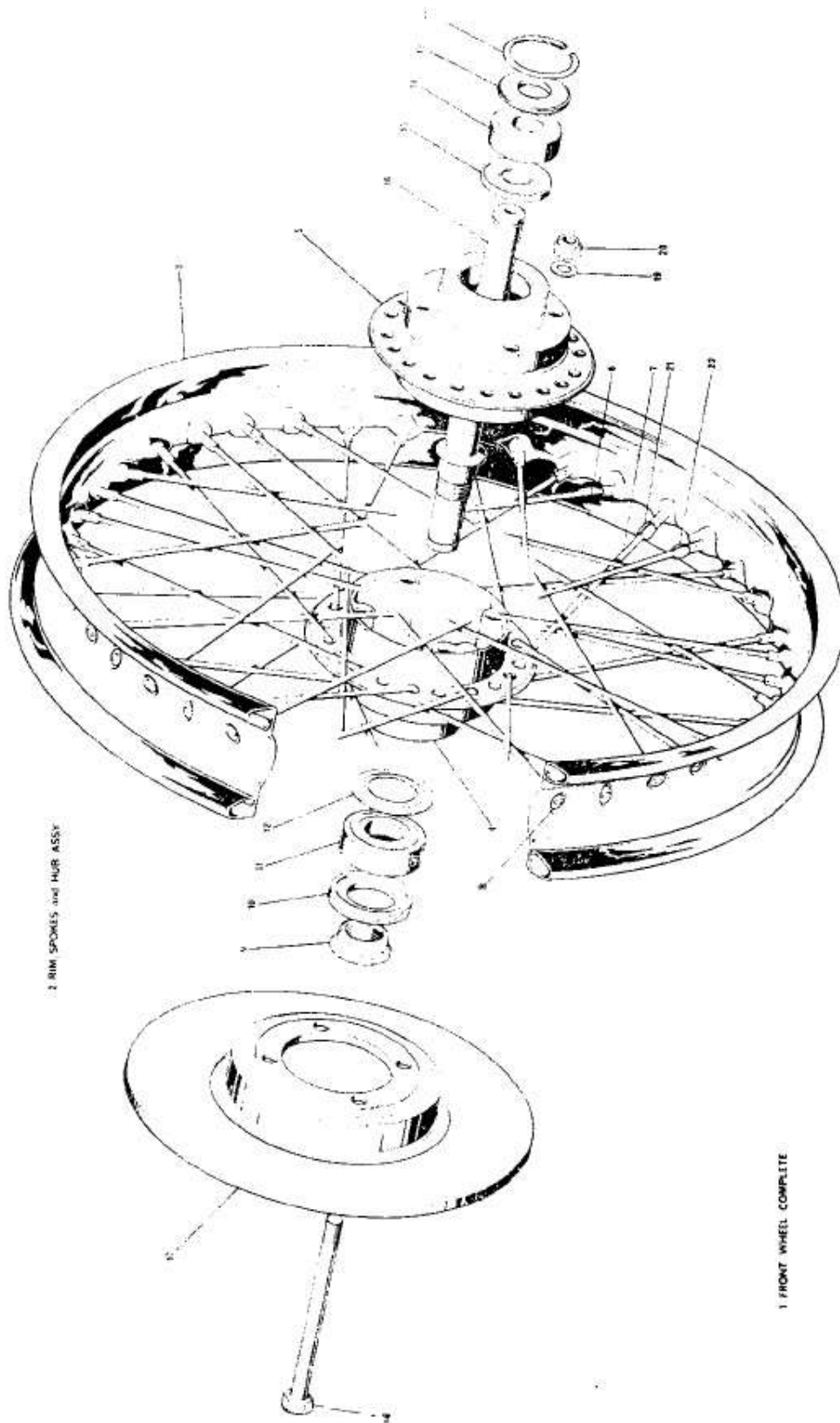

FIG. 22 FRONT WHEEL

FRONT WHEEL

Ref. No.	Part No.	Description	Quantity	Remarks
1	37-4141	FRONT WHEEL COMPLETE	1	
2	37-4143	RIM, SPOKES AND HUB ASSEMBLY	1	
3	37-4129	Rim WM2 x 19	1	
4	37-4126	Hub - left half	1	
5	37-4127	Hub - right half	1	
6	37-4131	Spoke - outer	20	
7	37-4130	Spoke - inner	20	
8	37-2294	Spoke nipple	40	
9	37-4133	Nut, wheel spindle	1	
10	37-4134	Lock ring - left	1	
11	37-7041	Bearing - left (metric 125)	1	
12	37-4135	Grease retainer - left	1	
13	37-1237	Dust cover - right	2	
14	37-7042	Bearing - right (metric 120)	1	
15	57-0280	Circlip - right	1	
16	37-4132	Spindle	1	
17	37-4275	Disc	1	
18	21-2207	Bolt	4	} Disc to hub
19	70-8770	Washer	4	
20	14-1903	Nut	4	
21	37-3969	Balance weight		As reqd.
22	37-3970	Balance weight		As reqd.

REF. 1 MASTER CYLINDER COMPLETE

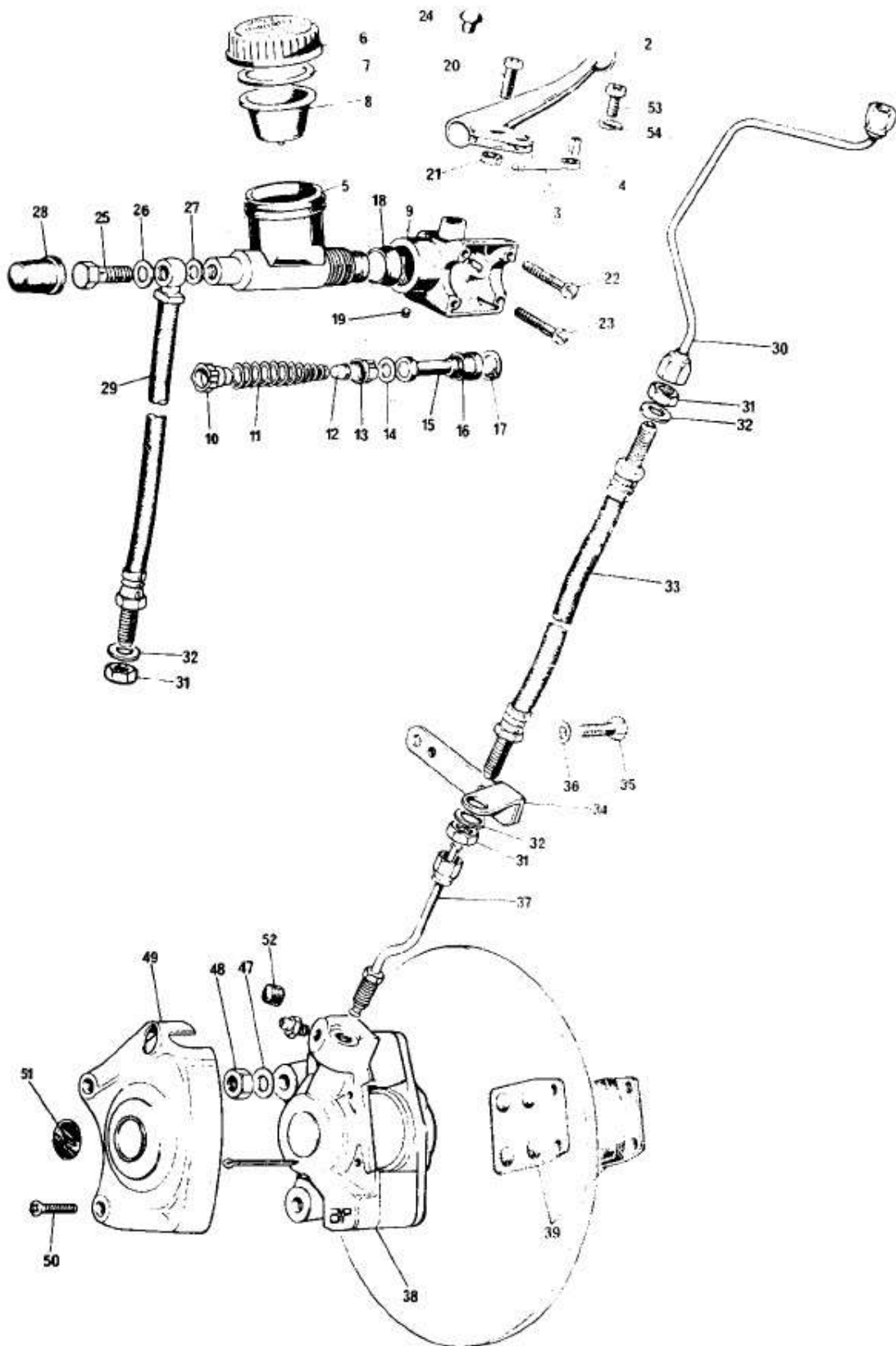

Fig. 23. FRONT BRAKE

FRONT BRAKE

Ref. No.	Part No.	Makers Part No.	Description	Quantity	Remarks
1	60-4102	4222-979	MASTER CYLINDER	1	
2	60-4206	-	Brake lever assembly	1	
3	AP.LTD	3761-270	Piston	1	
4	AP.LTD	3528-441	Spiral pin	1	
5	99-2770	4221-072	Barrel and tank assembly	1	
6	60-4365	3847-240	Cap	1	
7	60-4328	-	Washer	1	
8	60-4366	3818-747	Diaphragm	1	
9	99-2753	3338-901	Switch housing	1	
10	99-2754	4312-318	Trap valve	1	
11	99-2755	3118-234	Spring	1	
12	99-2756	3675-216	Spring retainer	1	
13	99-2757	3842-424	Primary cup	1	
14	99-2758	106418	Piston washer	1	
15	99-2759	3261-542	Piston	1	
16	99-2760	3871-473	Secondary cup	1	
17	99-2761	K29103	Circlip	1	
18	99-2762	3811-420	Rubber boot	1	
19	99-2763	3476-209	Grub screw	1	
20	21-2191	-	Pivot screw	1	
21	14-1201	-	Nut	1	
22	21-2192	-	Screw, short	2	
23	21-2194	-	Screw, long	2	
24	70-7573	-	Plug	1	
25	60-4183	AP40320	Banjo bolt	1	
26	60-4182	KL44516	Sealing washer	1	
27	60-4184	KL44518	Sealing washer	1	
28	60-4186	AP3187/810	Rubber boot	1	
29	60-4176	KL58505	Hose, master cylinder/top yoke	1	For high handlebar
29	60-4619	KL563	Hose, master cylinder/top yoke	1	For low handlebar
30	60-4179	ZT2071N	Pipe, top yoke/bottom yoke	1	
31	60-4180	K24103	Locknut	3	
32	70-2288	-	Washer	3	
33	60-4175	KL56612	Hose, bottom yoke/fork leg	1	
34	83-7064		Bracket - pipe support	1	
35	14-0103		Bolt	2	Bracket to fork leg and bridge piece
36	60-2427		Washer	2	
37	60-4178	ZTA2070N	Pipe, fork leg /caliper	1	
38	60-4101	4823-432	CALIPER	1	
39	99-2769	4741-570	Brake pad kit	2	
41	99-7006		Caliper seal kit	1	

REF. 1 MASTER CYLINDER COMPLETE

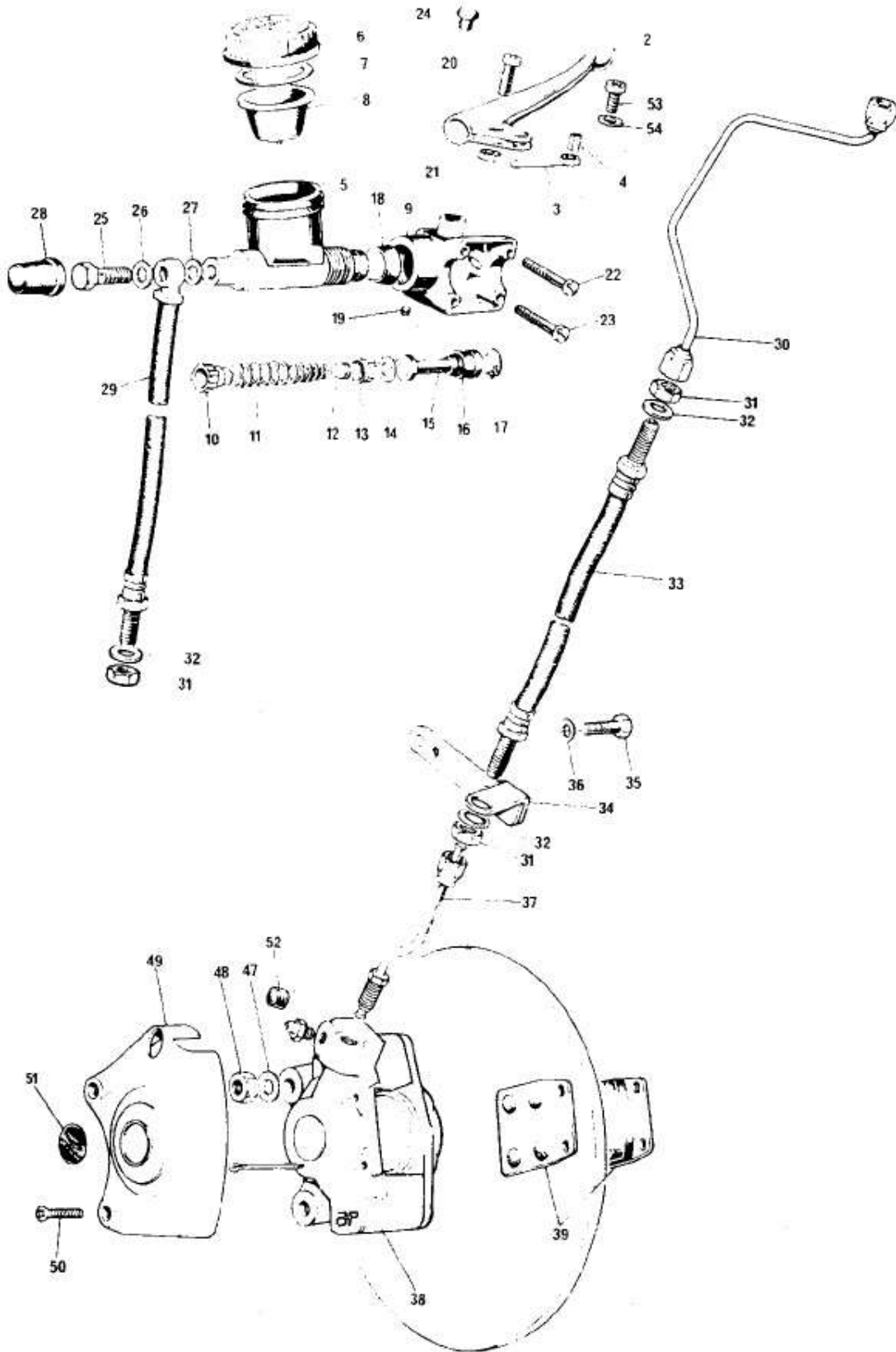
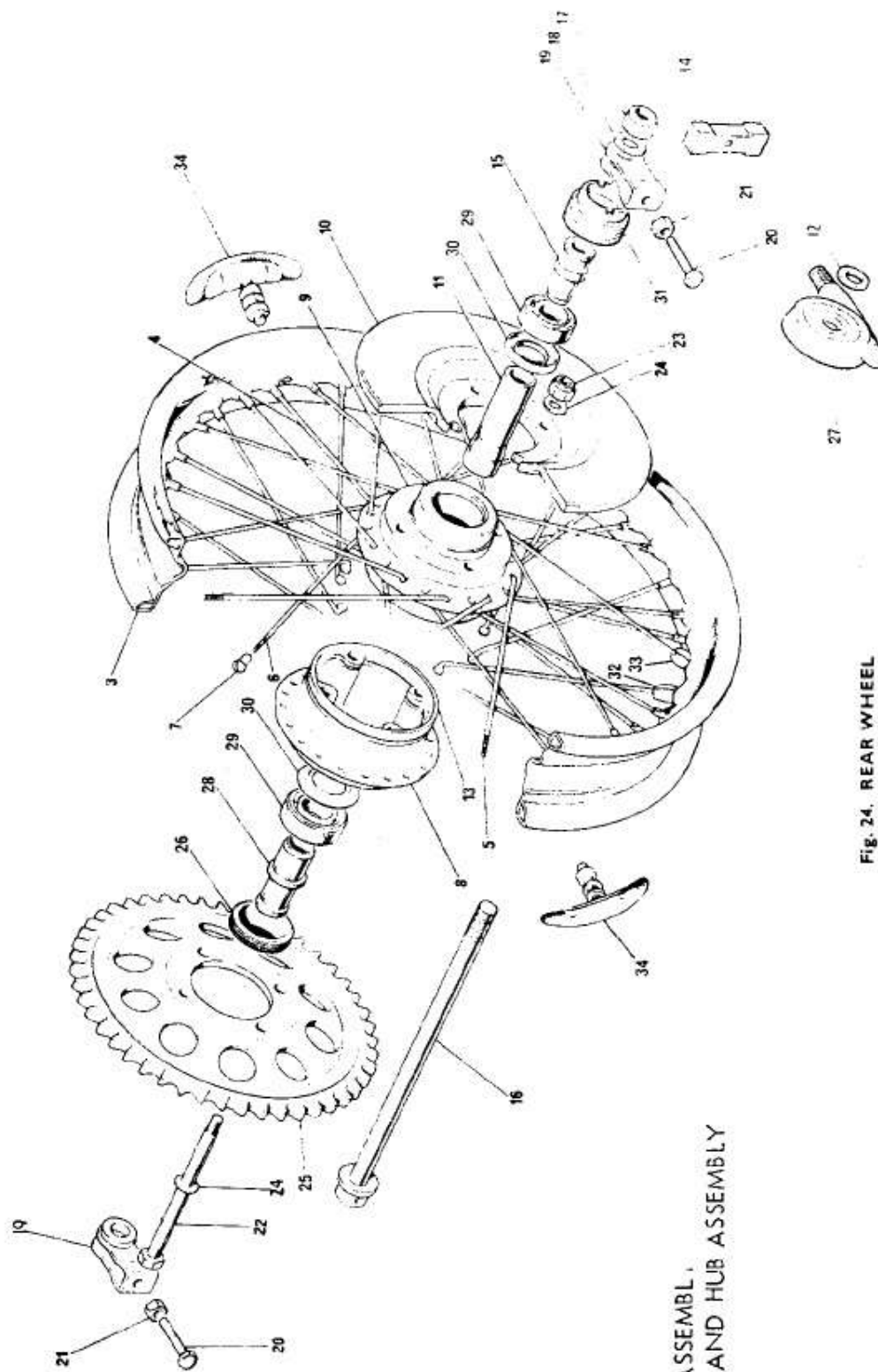

Fig. 23. FRONT BRAKE

Ref. No.	Part No.	Makers Part No.	Description	Quantity	Remarks
47	60-2331	-	Washer	2	} Caliper to outer member
48	14-1303	-	Nut	2	
49	37-4263	-	Cover, caliper	1	
50	21-2196	-	Screw, cover attachment	2	
51	60-4156	-	Decal, caliper cover	1	
52	60-4266	363-400	Cover, bleed nipple	1	} Girling part
53	21-1998	-	Screw, stop switch to lever body	1	
54	21-7008	-	Washer, for screw.	1	
	99-2768		Front master cyl. seal kit	1	



REF. 1 REAR WHEEL ASSEMBLY,
 REF. 2 RIM, SPOKES AND HUB ASSEMBLY

Fig. 24. REAR WHEEL

REAR WHEEL

Ref. No.	Part No.	Description	Quantity	Remarks
1	37-7035	REAR WHEEL ASSEMBLY	1	
2	37-7017	RIM, SPOKES AND HUB ASSEMBLY	1	
3	37-7030	Rim - W.M.3 - 18	1	
4	37-7031	Spoke, inner - right and left	20	
5	37-7032	Spoke, outer - right	10	
6	37-7033	Spoke, outer - left	10	
7	37-7034	Nipple	40	
8	37-7001	Hub - left half	1	
9	37-7002	Hub - right half	1	
10	37-4275	Disc	1	
11	37-7005	Spacer tube - bearings	1	
12	37-7021	Washer - speedometer drive gearbox		
13	37-7010	Centre spacer- rear hub	1	
14	83-3082	Cover plate - fork end	2	
15	37-7003	Spacer, - right bearing	1	
16	37-3965	Spindle	1	
17	14-1307	Nut - wheel spindle (5/8" UNF self locking)	1	
18	83-2266	Washer - wheel spindle nut (.656"-1.000"-.092")	1	
19	37-3742	Adjuster - chain	2	
20	14-0107	Screw - chain adjuster (1/4" UNF x 1 1/2" UH)	2	
21	14.0301	Nut - chain adjuster screw (1/4" UNF)	2	
22	21-7005	Bolt - disc to sprocket	4	
23	14-1903	Nut - disc/sprocket bolt (3/8" UNF self locking)	4	
24	70-8770	Washer - disc/sprocket nut (.390"-.625"-.064")	8	
25	37.7016	Sprocket - rear wheel 47T	1	
26	37-4134	Lock ring - left bearing	1	
27	60-3213	Speedometer drive unit	1	
28	37-7006	Spacer - left bearing	1	
29	57-1070	Bearing - left and right	2	
30	37-4135	Grease retainer	2	
31	37-7004	Driving ring - speedometer unit	1	
32	37-3969	Balance weight - short	As required	
33	37-3970	Balance weight - long	As required	
34	37-3468	Security bolt	2	
	37-7044	Sprocket - rear wheel 45T	As required - spares only	

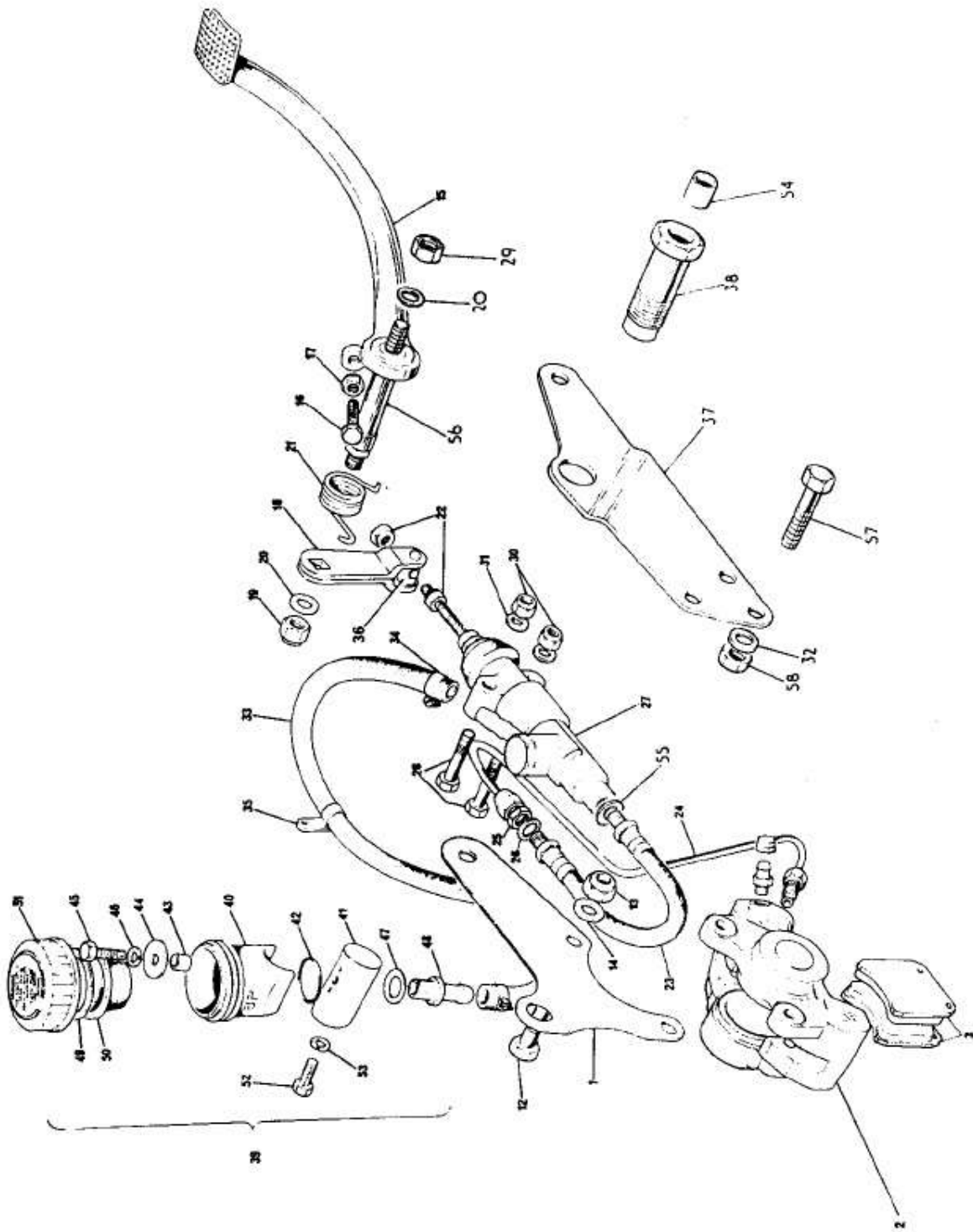

FIG. 25. REAR BRAKE

REAR BRAKE

Ref. No.	Part No.	Makers Part No.	Description	Quantity	Remarks
1	37-7020	-	Rear caliper mounting plate	1	
2	60-4101	4823-432	CALIPER	1	
3	99-2769	4741-570	Brake pad kit	1	
6	9912765	3275-428	Piston	2	
12	14-0232	-	Bolt, caliper to mounting	2	
13	14-1203	-	Nut, caliper to mounting plate bolt	2	
14	82-2184	-	Washer, for nut	2	
15	83-7044	-	Brake pedal	1	
16	14-0103	-	Screw, adjuster - stop light	1	1/4" UNF x 3/8" U.H.
17	14-0301	-	Nut, adjuster screw	1	1/4" UNF
18	83-7003	-	Trunnion lever	1	
19	14-1303	-	Nut - brake pedal spindle, inner	1	
20	60-2331	-	Washer, for nut	2	
21	83-7016	-	Return spring, brake pedal	1	
22	21-7006	-	Adjuster nut, push rod	2	5/16" UNF shouldered
23	60-7028	-	Hose, master cylinder to pipe	1	
24	60-7007	ZTA2281	Pipe, hose to caliper	1	
25	60-4180	K24103	Nut, hose to bracket	1	
26	70-2288	K19407	Serrated washer, hose to bracket	1	
27	60-4401	4211-127	MASTER CYLINDER COMPLETE	1	
28	21-7007	-	Bolt, master cylinder fixing	2	
29	14-1903	-	Nut, brake pedal spindle, outer	1	
30	14-1302	-	Nut, cylinder to frame bolt	2	5/16" UNF self locking
31	60-2330	-	Washer for nut	2	
32	60-2330	-	Washer for master cylinder fixing, rear	1	
33	60-4409	9206-2050	Hose, reservoir to master cylinder	1	
34	60-7030	-	Clip, hose	2	
35	83-7049	-	Clip, hose	1	
36	83-7024	-	Trunnion	1	
37	83-7018	-	Mounting plate, master cylinder	1	
38	83-7053	-	Pivot bolt assembly with bushes	1	
39	83-5465	-	Reservoir assembly	1	
40	60-4397	3251/796	Body, reservoir	1	
	99-7006		Caliper seal kit		

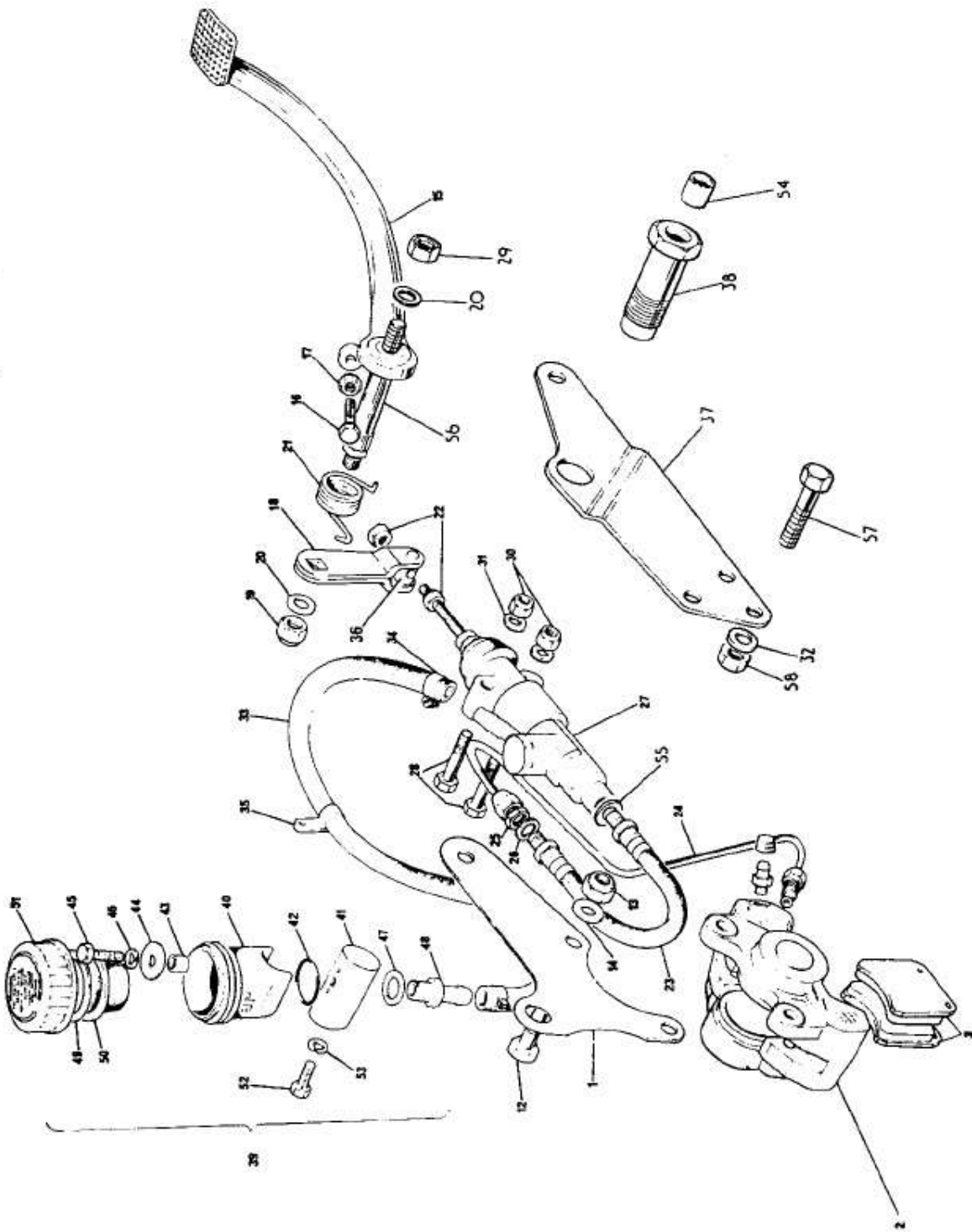

FIG. 25. REAR BRAKE

REAR BRAKE (continued).

Ref. No.	Part No.	Makers Part No.	Description	Quantity	Remarks
41	83-7056	-	Mounting, reservoir	1	
42	60-4374	3855/814	'O' ring	1	
43	60-4398	3517/221	Distance piece	1	
44	60-4399	3512/305	Washer	1	
45	14-0102	-	Bolt, body to mounting	1	1/4" UNF x 5/8" UH
46	60-2427	-	Spring washer for bolt	1	
47	60-7016	-	Sealing washer	1	
48	83-7055	-	Outlet stub, feed hose	1	
49	60-4328	-	Washer, paper	1	
50	60-4366	3818-747	Diaphragm	1	
51	60-4365	3847-240	Filler cap	1	
52	14-0101	-	Bolt, mounting to coil tray	1	1/4" UNF x 5/8" UH
53	60-2427	-	Washer, for bolt	1	
54	83-7054	-	Pivot bolt bush	2	Ref only
55	60-4182	-	Copper gasket	1	
56	83-7046	-	Spindle, rear brake pedal	1	
57	14-0114	-	Bolt, master cylinder/plate fixing rear	1	
58	14-1302	-	Nut for bolt	1	
	99-2768	-	Rear master cyl. seal kit	1	

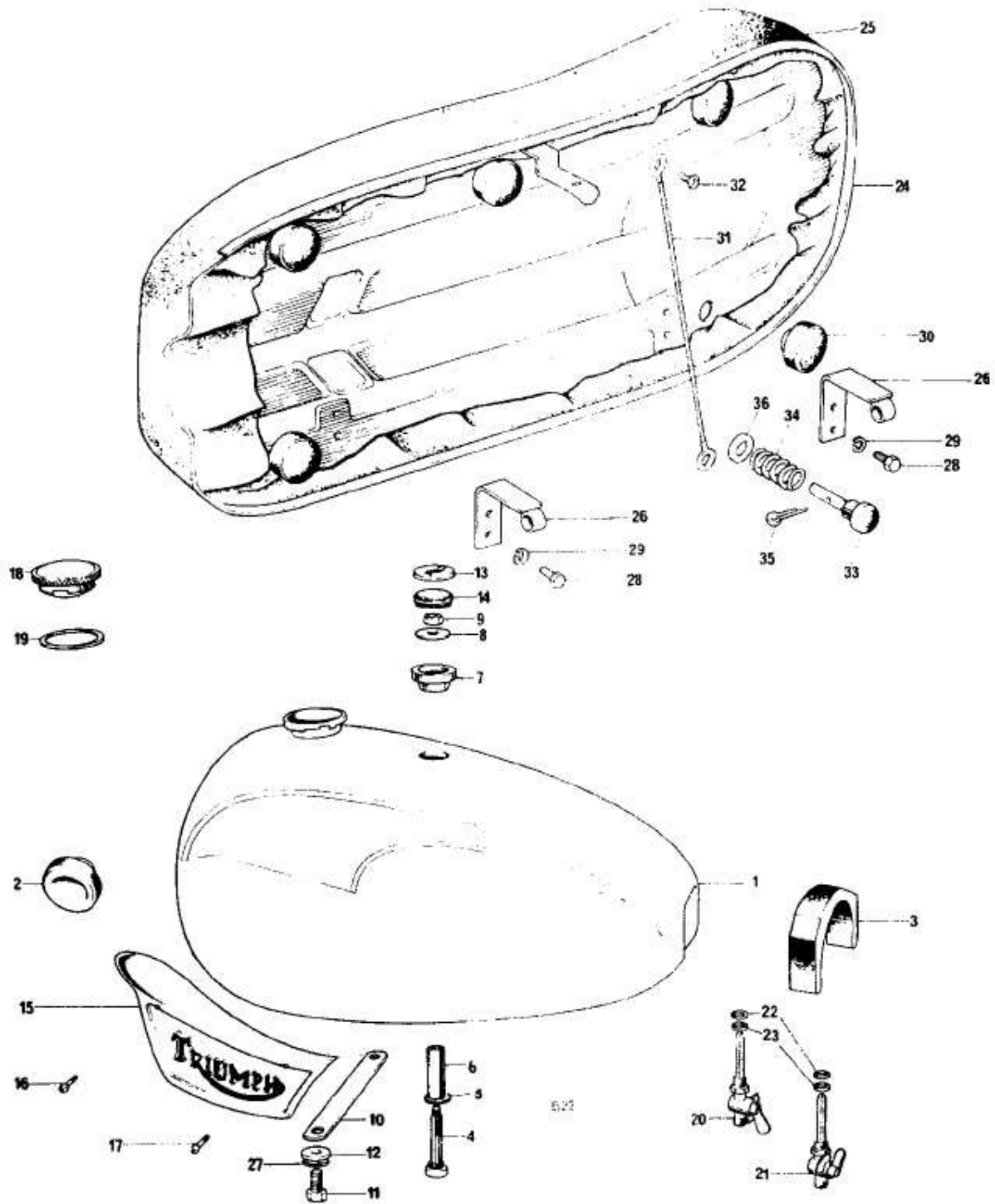

Fig. 25 GAS TANKS AND TWINSEAT

GAS TANK AND TWINSEAT

Ref. No.	Part No.	Description	Quantity	Remarks
1	83-7111	Gas tank (3.6 US galls) Black & candy apple red	1	T140V
1	83-7112	" " " " Astral blue & silver	1	T140V
1	83-7113	" " " " Tawny brown & gold	1	T140V
1	83-7114	" " " " Candy apple red & white	1	TR7RV
1	83-7115	" " (4.0 Imp gall) Tawny brown & gold	1	T140V
1	83-7116	" " " " Aquamarine & silver	1	T140V
1	83-7117	" " " " Candy apple red & silver	1	TR7RV
1	83-7118	" " " " Burnished gold & silver	1	TR7RV
2	83-4931	Steady rubber	2	
3	83-4932	Mounting rubber	2	
4	83-4930	Centre fixing bolt	1	
5	60-2320	Washer	1	
6	82-9063	Distance tube	1	
7	83-4934	Mounting rubber	1	
8	83-3814	Washer	1	
9	14-0302	Nut	1	
10	83-4395	Tie strap	1	
11	14-0113	Bolt	2	
12	60-2321	Washer	2	
13	83-4776	Badge - tank grommet	1	
14	83-4763	Grommet	1	
15	82-9700	Tank motif - right	1	
15	82-9701	Tank motif - left	1	
16	83-1339	Screw - front - tank motif	2	
17	82-7888	Screw - rear - tank motif	2	
18	83-3875	Filler cap	1	
19	82-4048	Joint washer	1	
20	60-4511	Gas tap - main	1	
21	60-4512	Gas tap-reserve	1	
22	70-7351	Tap seal	2	
23	83-0002	Washer	2	
24	83-7127	Twinseat assy (Black)	1	use with 3.6 gall tank
	83-7128	" " " "	1	" 4.0 " "
	83-7129	" " (Brown)	1	use with 3.6 gall tank
	83-7130	" " " "	1	" 4.0 " "
25	83-7131	Cover twinseat (Black)	1	use with 3.6 gall tank
	83-7132	" " " "	1	" 4.0 " "
	83-7133	" " (Brown)	1	use with 3.6 gall tank
	83-7134	" " " "	1	" 4.0 " "
26	83-4782	Hinge - front and rear	2	
27	60-2428	Spring washer	2	
28	14-0101	Bolt	4	} Hinge attachment
29	60-2417	Washer	4	
30	82-9093	Rubber buffer	4	
31	60-2087	Check wire	1	
32	60-2381	Screw - self tapping	1	
33	82-7560	Seat plunger and knob	1	
34	82-4228	Spring	1	
35	60-2720	Split pin (3/32 in. x 1/2 in.)	1	
36	71-3749	Washer	1	
16	21-2064	Screw - tank badge	4	For 4 gall tank only
15	60-2569	Tank badge	2	" " " " "
	83-4355	Knee grip - left	1	" " " " "
	83-4356	Knee grip - right	1	" " " " "
10	83-4118	Tie strap	1	" " " " "

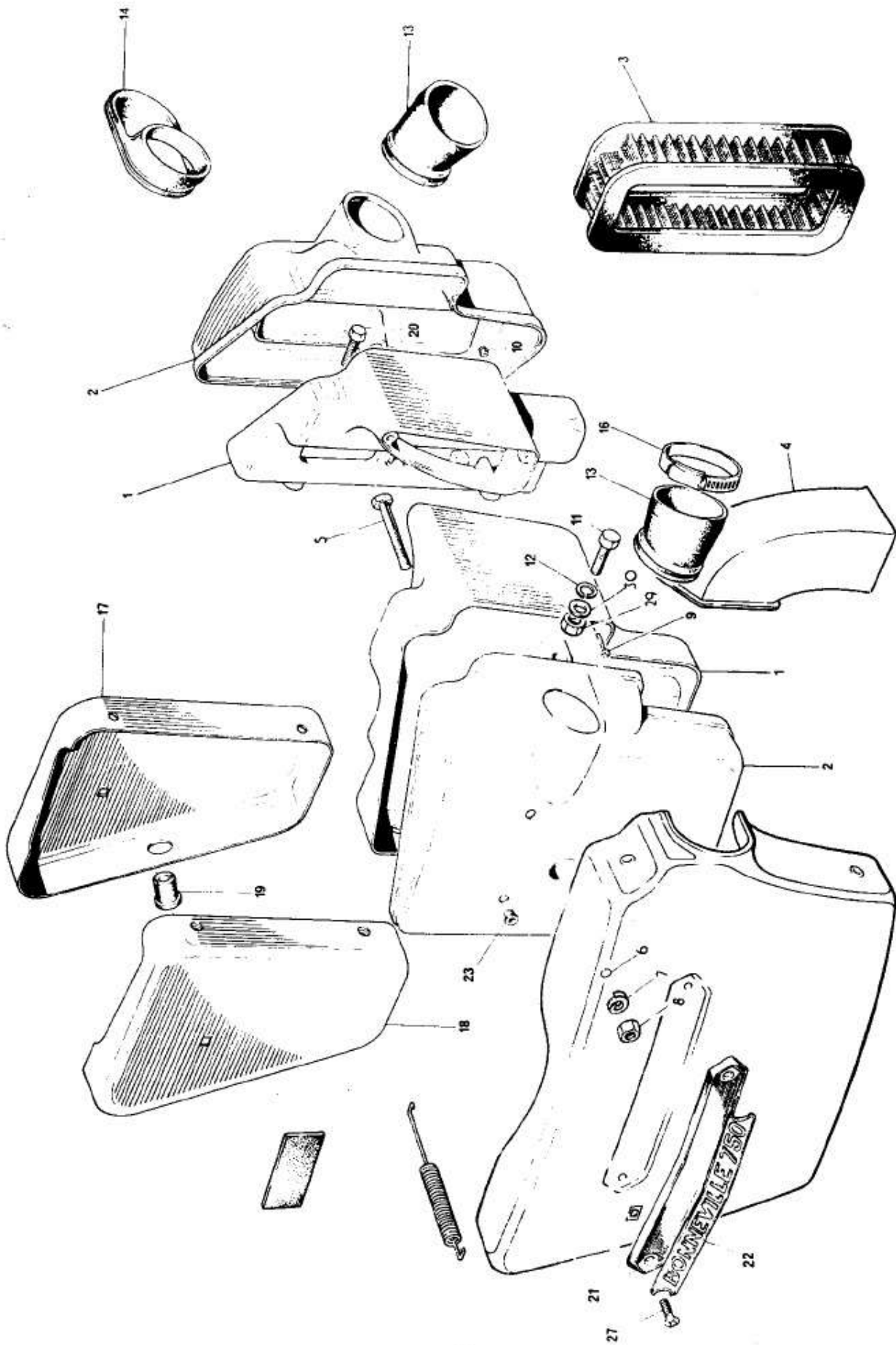

Fig. 26 AIR CLEANERS AND SIDE PANELS

AIR CLEANER AND SIDE PANELS

Ref. No.	Part No.	Description	Quantity	Remarks
1	83-4606	Body - left	1	Twin Carb T140V
1	83-4607	Body - right	1	
2	83-7067	Cover - left	1	Single Carb TR7RV
2	83-7068	Cover - right	1	
1	83-4845	Body - left	1	All models
1	83-4609	Body - right	1	
2	83-4807	Cover - left	1	2
2	83-4808	Cover - right	1	
3	60-4265	Element	2	1
4	83-5448	Air intake tube, left	1	
4	83-5449	Air intake tube, right	1	2
5	14-0221	Bolt	2	
6	82-8245	Retainer	2	2
7	60-2438	Washer	2	
8	14-0302	Nut	2	2
9	60-3539	Screw	2	
10	21-0501	Nut left assy to right assy	2	2
13	71-7019	Connector pipe Air filter to engine	2	
14	83-5161	Connector pipe	1	T140V
15	71-1860	Carburetor adaptor	1	TR7RV
16	60-3975	Clip	1	TR7RV
16	71-7018	Clip	2	T140V
17	83-4854	Side panel - left	1	
18	83-4803	Side panel - right	1	
19	82-6673	Panel grommet	2	
20	14-0102	Bolt	4	
21	60-4150	Name plate	2	
22	60-7055	Motif "Tiger 750"	2	TR7RV
22	60-7054	Motif "Bonneville 750"	2	T140V
23	60-4153	Rubber bush	4	
26	21-7020	Spire SNP.0164	4	
27	82-4129	Screw	4	
29	14-1302	Nut	2	
30	60-2321	Plain washer	2	
31	14-0218	Bolt		
	82-7380	Rubber pad - under styling panel	2	
	83-7070	Spring - styling panel fixing	4	
	83-7097	Styling side panel L. H. Black	T140V	
	83-7098	" " " R. H. "	"	
	83-7099	" " " L. H. Tawny brown	"	
	83-7100	" " " R. H. " "	"	
	83-7101	" " " L. H. Aquamarine	"	
	83-7102	" " " R. H. "	"	
	83-7103	" " " L. H. Black	TR7RV	
	83-7104	" " " R. H. "	"	
	83-7105	" " " L. H. Candy apple & silver	"	
	83-7106	" " " R. H. " " "	"	
	83-7107	" " " L. H. Burnished gold & silver	"	
	83-7108	" " " R. H. " " "	"	

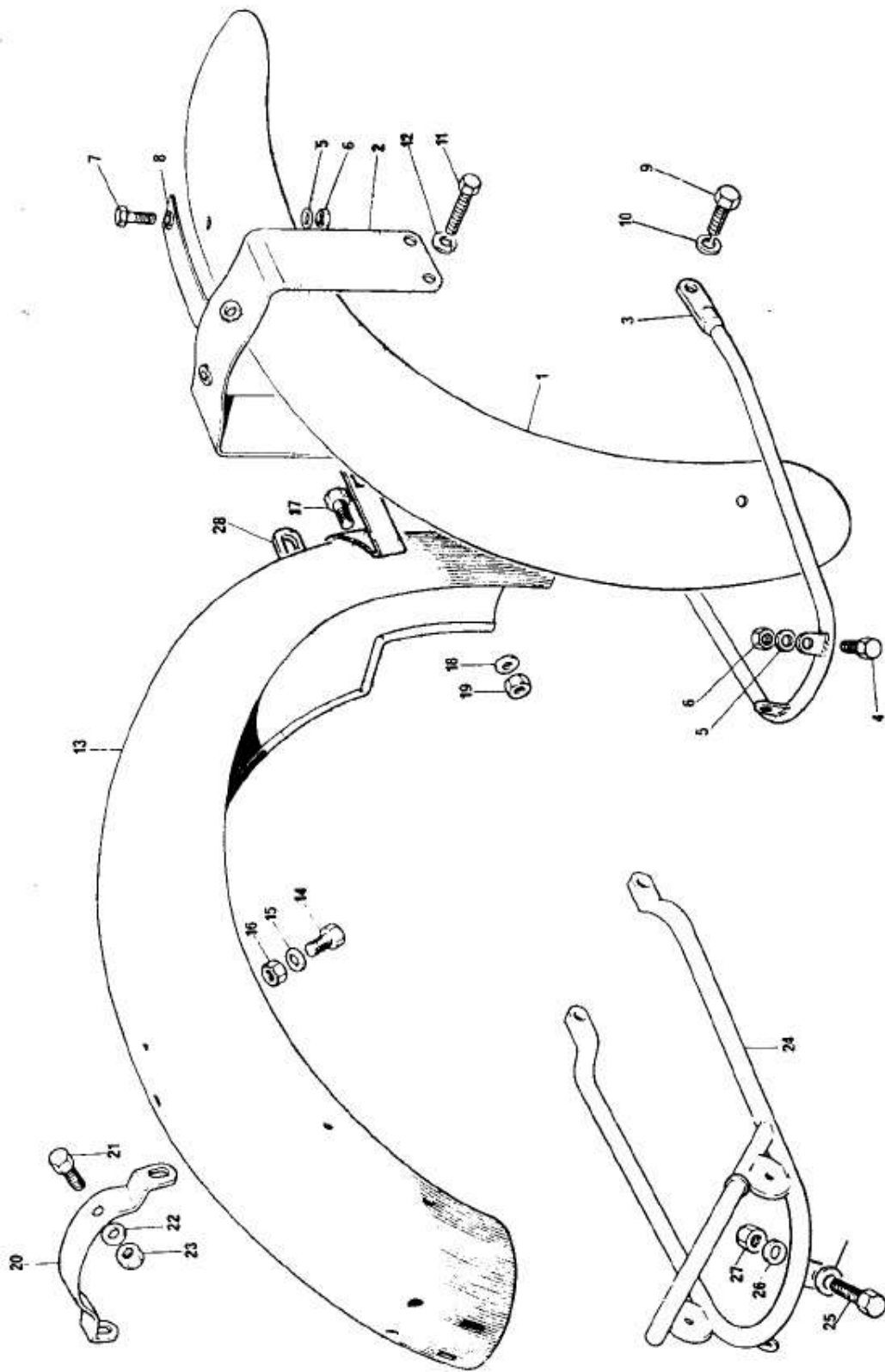

Fig. 27. FENDERS AND TAIL LAMP

FENDERS

Ref. No.	Part No.	Description	Quantity	Remarks
1	97-7003	Front fender chrome	1	
1	97-7012	" " Tawny brown & gold	1	
1	97-7013	" " Aquamarine & silver	1	
1	97-7014	" " Candy apple red & silver	1	
1	97-7015	" " Burnished gold & silver	1	
2	97-7004	Bridge piece assembly	1	
3	97-4552	Rear stay	1	
4	14-0101	Bolt, rear stay to blade	2	
5	60-4245	Washer	5	
6	14-1201	Nut	5	
7	14-2205	Screw, bridge piece to blade	3	
8	21-7025	Washer nylon	8	
9	14-6114	Bolt, stay to spindle cap	2	
10	60-2428	Washer	2	
11	14-0103	Bolt, bridge piece to fork leg	2	
12	60-2427	Washer	2	
13	83-7031	Rear fender	1	
13	83-7131	Rear fender chrome	1	
13	83-7123	" " Tawny brown	1	
13	83-7124	" " Aquamarine & silver	1	
13	83-7125	" " Candy apple red & silver	1	
13	83-7125	" " Burnished gold & silver	1	
14	14-0101	Bolt	2	Fender top fixing
15	60-2329	Washer	2	
16	14-1301	Nut	2	
17	14-0114	Bolt	2	Fender front fixing
18	60-2330	Washer	2	
19	14-1302	Nut	2	
20	83-4600	Bridge - rear fender	1	
21	14-0102	Bolt	2	Bridge to fender
22	60-2329	Washer	2	
23	14-1301	Nut	2	
24	83-5145	Grab rail	1	Grab rail to fender
25	14-0102	Bolt	2	
26	60-2329	Washer	2	
27	14-1301	Nut	2	
28	83-2796	Lower front bracket	1	

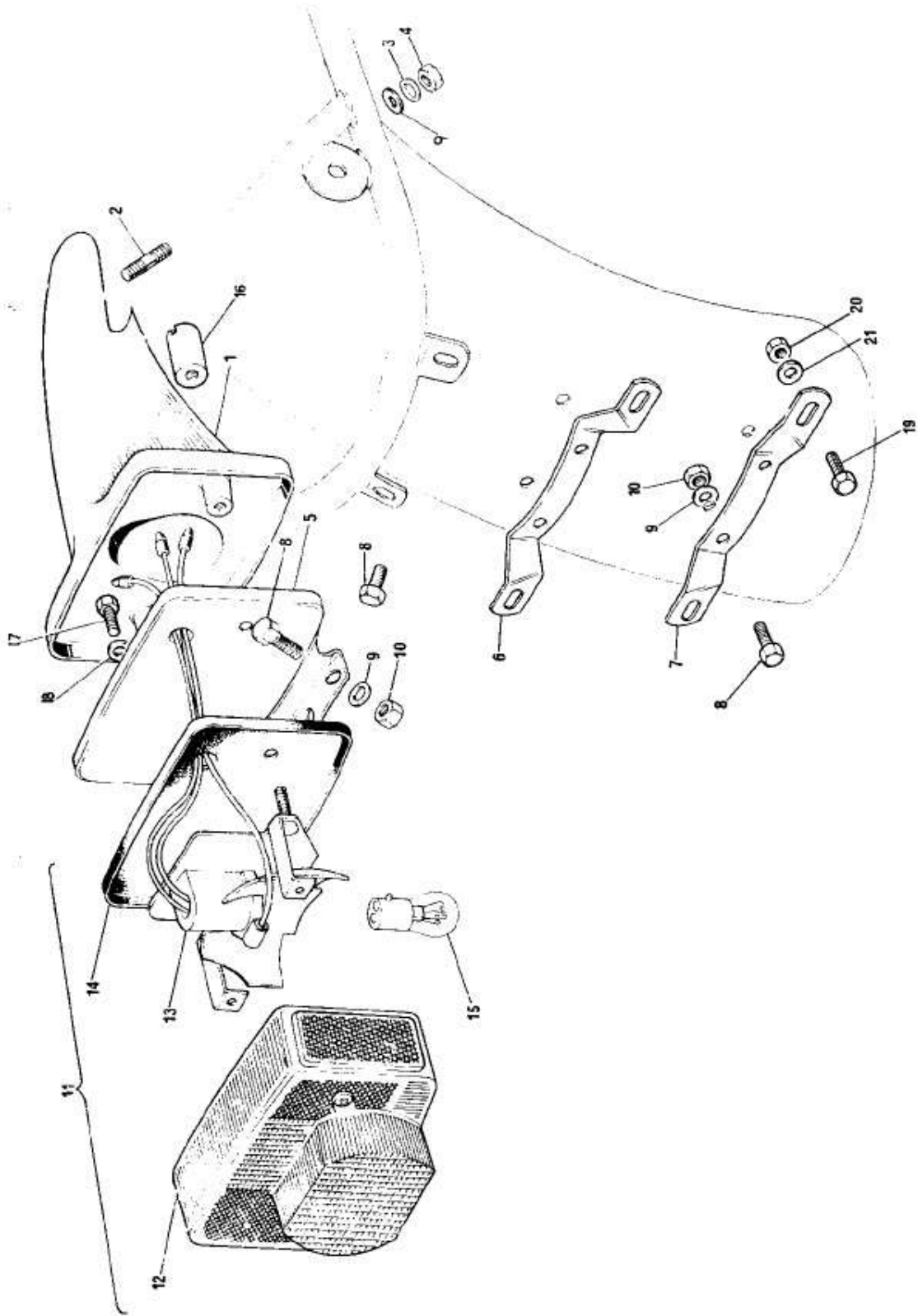

Fig. 28. TAIL LAMP AND SUPPORT

TAIL LAMP AND SUPPORT

Ref. No.	Part No.	Makers Part No.	Description	Quantity	Remarks
1	83-7094	-	Tail lamp carrier	1	
2	21-2225	-	Stud	1	Tail lamp support to fender
3	60-4250	-	Washer	1	
4	14-0301	-	Nut	1	
5	83-5001	-	Support plate	1	
6	83-4784	-	Rear No. plate bracket - top	1	
7	82-6850	-	Rear No. plate bracket - bottom	1	No. plate bracket and support plate to fender
8	14-0102	-	Bolt	1	
9	60-2329	-	Washer	4	
10	14-1301	-	Nut	5	
11	06-8029	56515	STOP TAIL LAMP	4	
12	06-8058	54585314	Lens	1	
13	Lucas	54584931	Base assembly	1	
14	Lucas	54583924	Gasket	1	
15	99-0542	380	Bulb	1	
16	83-4800	-	Sleeve nut, lamp to back plate	1	
17	14-7804	-	Screw support plate to carrier	2	
18	70-1612	-	Serrated washer	1	Not illustrated
	83-4806	-	Wiring protector	1	
	60-4103	-	Grommet, flasher wire	1	
	60-3748	-	Decal '5 speed'	1	
	83-5105	-	'U' grommet, lamp carrier	1	
	97-0961	-	Grommet, mudguard for wiring	2	
	60-4440	-	Grommet, flasher wires	2	
				2	
19	14-0101	-	Bolt - number plate attachment	4	
20	14-1301	-	Nut	4	
21	60-2329	-	Washer	4	

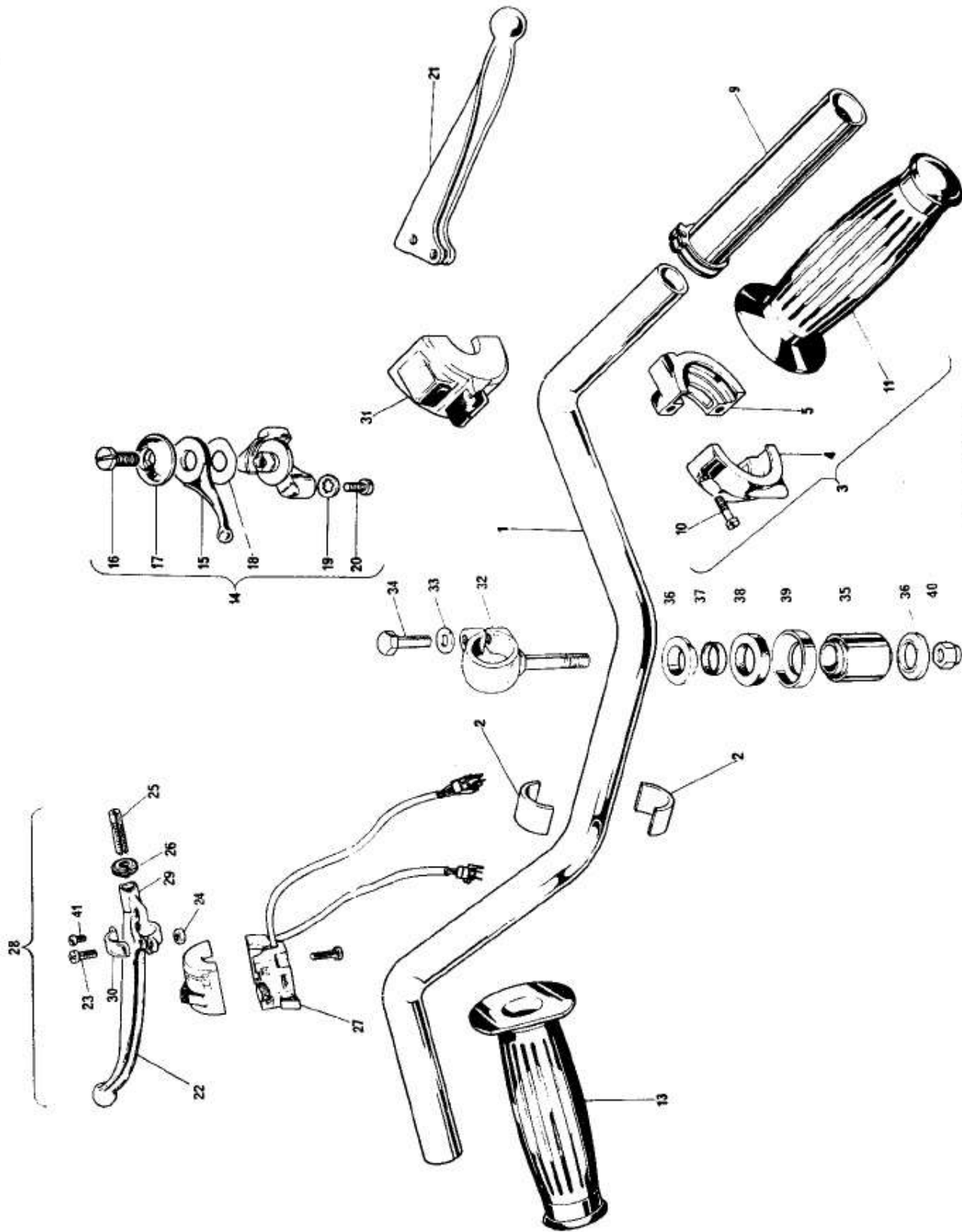

Fig. 29. HANDLEBAR AND CONTROL LEVERS

HANDLEBARS AND CONTROL LEVERS

Ref. No.	Part No.	Makers Part No.	Description	Quantity	Remarks
1	97-7001	-	Handlebar	1	USA specification
1	97-7002	-	Handlebar	1	UK and General
2	97-1425	-	Sleeve, handlebar mounting	4	
3	60-7014	364/18	TWIST GRIP	1	
4	Amal	16/328	Body, top half	1	
5	Amal	16/329	Body, bottom half	1	
9	Amal	-	Rotor	1	
10	99-0225	11/013	Screw	2	
11	97-2125	-	Grip, right hand	1	
13	97-2142	-	Grip, left hand	1	
14	60-3567	-	AIR CONTROL LEVER	1	
15	Amal	12/556	Lever	1	
16	Amal	12/607	Bolt	1	
17	Amal	12/606	Cap	1	
18	Amal	12/033	Spring washer	1	
19	70-1612	-	Shakeproof washer	2	
20	60-3896	-	Screw	2	
21	60-4206	-	Front brake lever assembly	1	
22	60-7023	-	Clutch lever blade	1	
23	60-7026	-	Pivot pin	1	
24	14-1901	-	Nut, pivot pin	1	
25	60-3585	-	Adjuster	1	
26	60-3586	-	Lockring	1	
27	19-1965	30447	HANDLEBAR SWITCH, LEFT HAND	1	
28	60-7021	-	CLUTCH LEVER ASSEMBLY COMPLETE	1	
29	60-7022	-	Handlebar bracket, clutch lever	1	
30	60-7024	-	Handlebar clamp for bracket	1	
31	19-1961	30781	Handlebar switch, right hand	1	
32	97-2291	-	Handlebar eyebolt	2	
33	82-1335	-	Washer	2	
34	21-0589	-	Bolt	2	
35	97-1527	-	Metalastik bush	2	
36	97-1529	-	Hemispherical washer	4	
37	97-1581	-	Distance piece	2	
38	97-1580	-	Rubber washer	2	
39	97-2221	-	Cup	2	
40	14-1303	-	Nut	2	
41	60-7025	-	Screw, handlebar clamp 5/8" x 1BA	2	

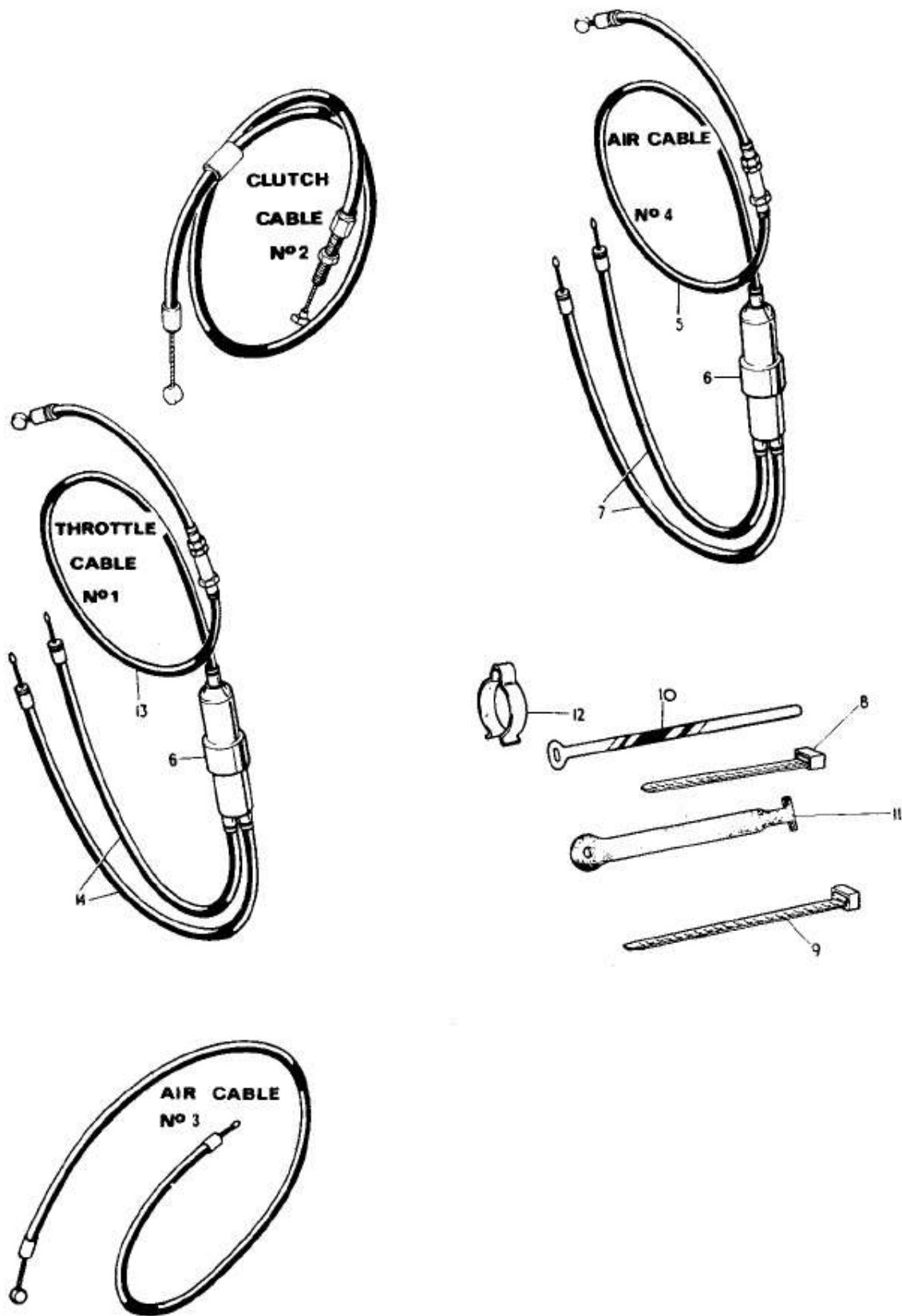

Fig. 30. CONTROL CABLES

CONTROL CABLES

Ref. No.	Part No.	Description	Quantity	Remarks
1	60-7002	Throttle cable COMPLETE	1	T140V HIGH BAR
1	60-7061	Throttle cable COMPLETE	1	TR7RV HIGH BAR
2	60-3925	Clutch cable COMPLETE	1	HIGH BAR
3	60-4194	Air control cable COMPLETE	1	TR7RV UNIVERSAL
4	60-4126	AIR CONTROL CABLE COMPLETE	1	T140V UNIVERSAL
5	60-4127	Air cable, lever to junction box	1	T140V UNIVERSAL
6	60-0685	Junction box throttle and air control	2	T140V UNIVERSAL
7	60-4128	Air cable, junction box to carburetor	1	T140V UNIVERSAL
8	60-0978	Cable clip	1	
9	60-4254	Cable clip	13	
10	60-0777	Cable clip	1	
11	60-4258	Cable clip	2	
12	97-4112	Handlebar clip	As required	
13	60-7001	Throttle cable (twist grip to junction block)	1	T140V HIGH BAR
14	60-0733	Throttle cable (junction block to carburetor)	2	T140V HIGH BAR

ALTERNATIVE FITMENTS

1	60-7058	Throttle cable COMPLETE	1	T140V LOW BAR
1	60-7060	Throttle cable COMPLETE	1	TR7RV LOW BAR
2	60-4168	Clutch cable COMPLETE	1	LOW BAR
13	60-7059	Throttle cable (twist grip to junction block)	1	T140V LOW BAR
14	60-0733	Throttle cable (junction block to carburetor)	2	T140V LOW BAR

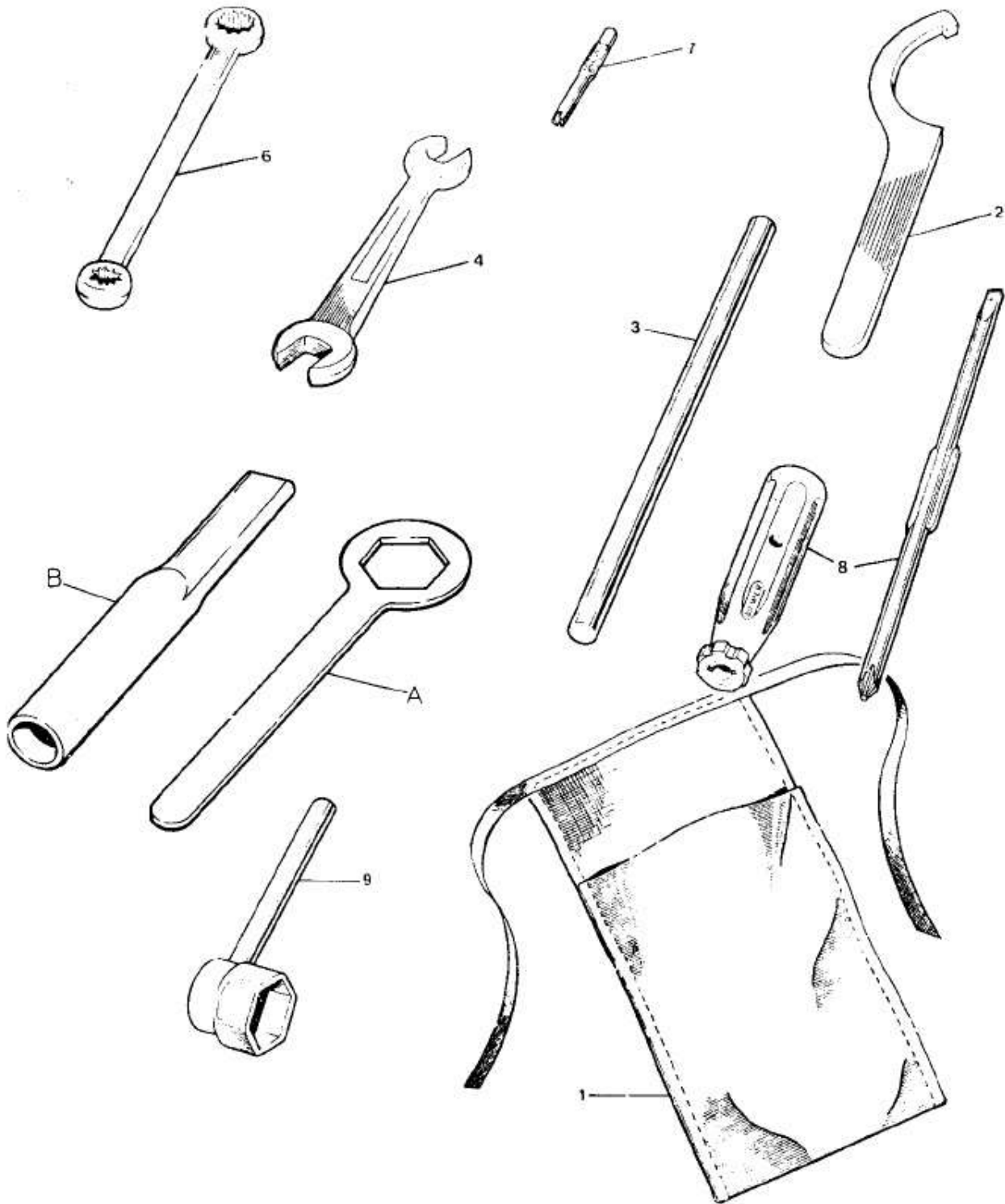

F.g. 31. TOOLKIT

TOOLKIT

Ref. No.	Part No.	Description	Quantity	Remarks
	60-7019	TOOKLIT COMPLETE	1	
1	60-0291	Tool roll	1	
2	60-2184	Damper unit spanner	1	
3	60-7041	Tommy bar, for rear wheel	1	
4	60-2084	Spanner - open ended	1	
6	60-1907	Ring spanner	1	
7	60-0974	Tyre valve key	1	
8	60-0767	Screw driver	1	
9	60-1050	Plug spanner	1	
A	60-7068	Rear wheel spanner	1	
B	60-7069	Lever for spanner	1	

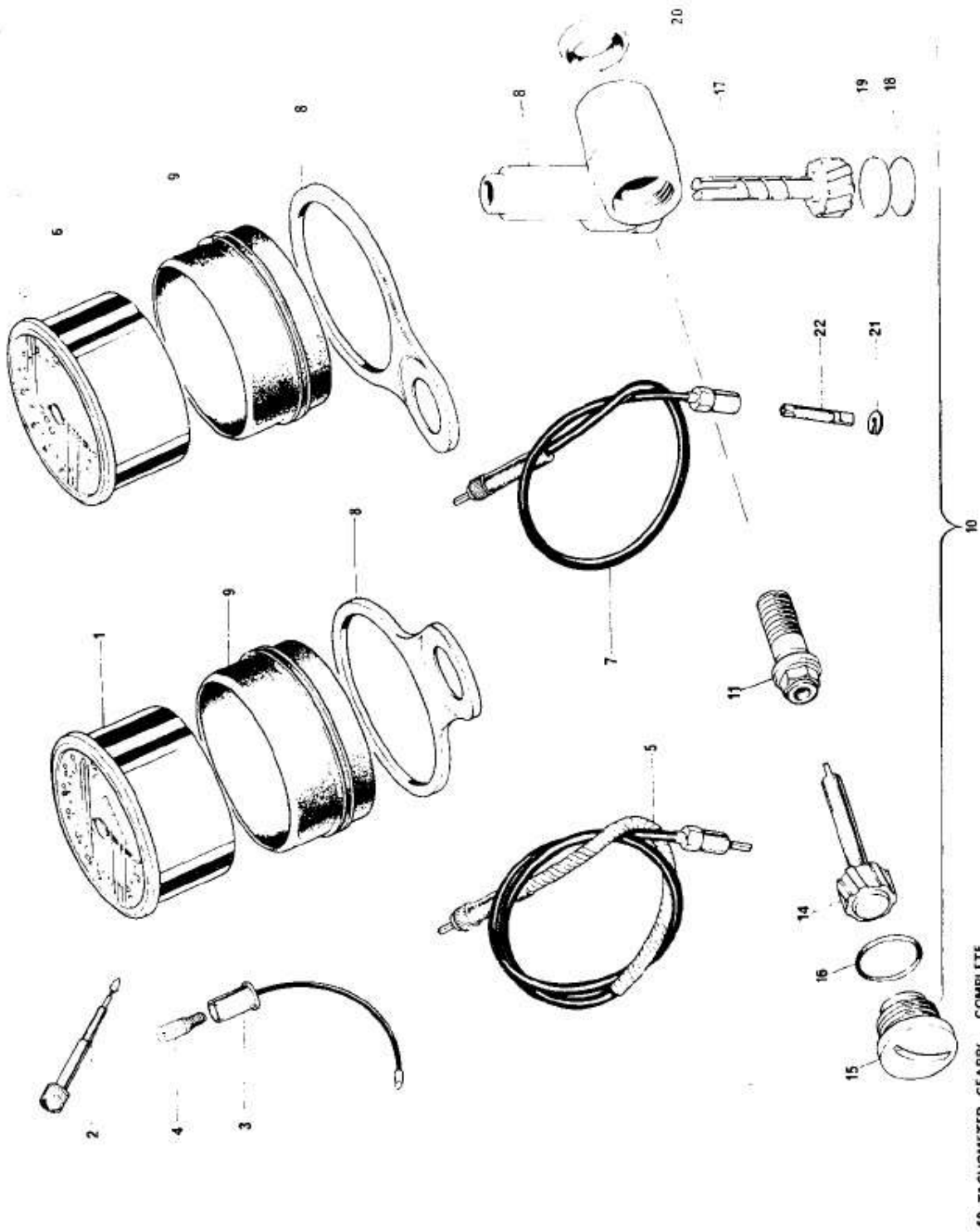

Fig. 32. SPEEDOMETER AND TACHOMETER

SPEEDOMETER AND TACHOMETER

Ref. No.	Part No.	Makers		Description	Quantity	Remarks
		Part No.				
1	06-5638	SSM4003/00		Speedometer head - MPH	1	
1	60-7027	SSM4003/01		Speedometer head - KPH	1	
2	60-7011	41-118-126-47		Trip control	1	
3	Lucas	51271406		Bulb holder	1	
4	Lucas	643		Bulb	1	
5	60-7012	DF9110/00		Speedometer cable	1	
6	60-7010	RSM3006/00		Tachometer head	1	
7	60-7013	DF9111/03		Tachometer cable	1	
8	97-4026	-		Mounting bracket	2	
9	60-2600	-		Rubber cup	2	
10	71-7011	-		TACHOMETER GEARBOX	1	
11	70-9332	-		Securing screw Assy	1	
12	70-5156	-		Bush	1	Reference only not supplied separately Part of 70-9332.
13	70-5155	-		Flanged bush	1	
14	70-5157	-		Driving gear	1	
15	71-2480	-		End cup	1	
16	60-3355	-		'O' ring	1	
17	71-2653	-		Driven gear	1	
18	71-2481	-		Welch washer	1	
19	71-7012	-		Thrust cap	1	
20	70-7351	-		Sealing washer	1	
21	60-0494	-		Circlip	1	
22	99-0173	31-371-398		Spade	1	
	60-2391	-		Washer	4	4) For speedo and Tacho
	21-0778	-		Nut	4	4) Mounting not illustrated

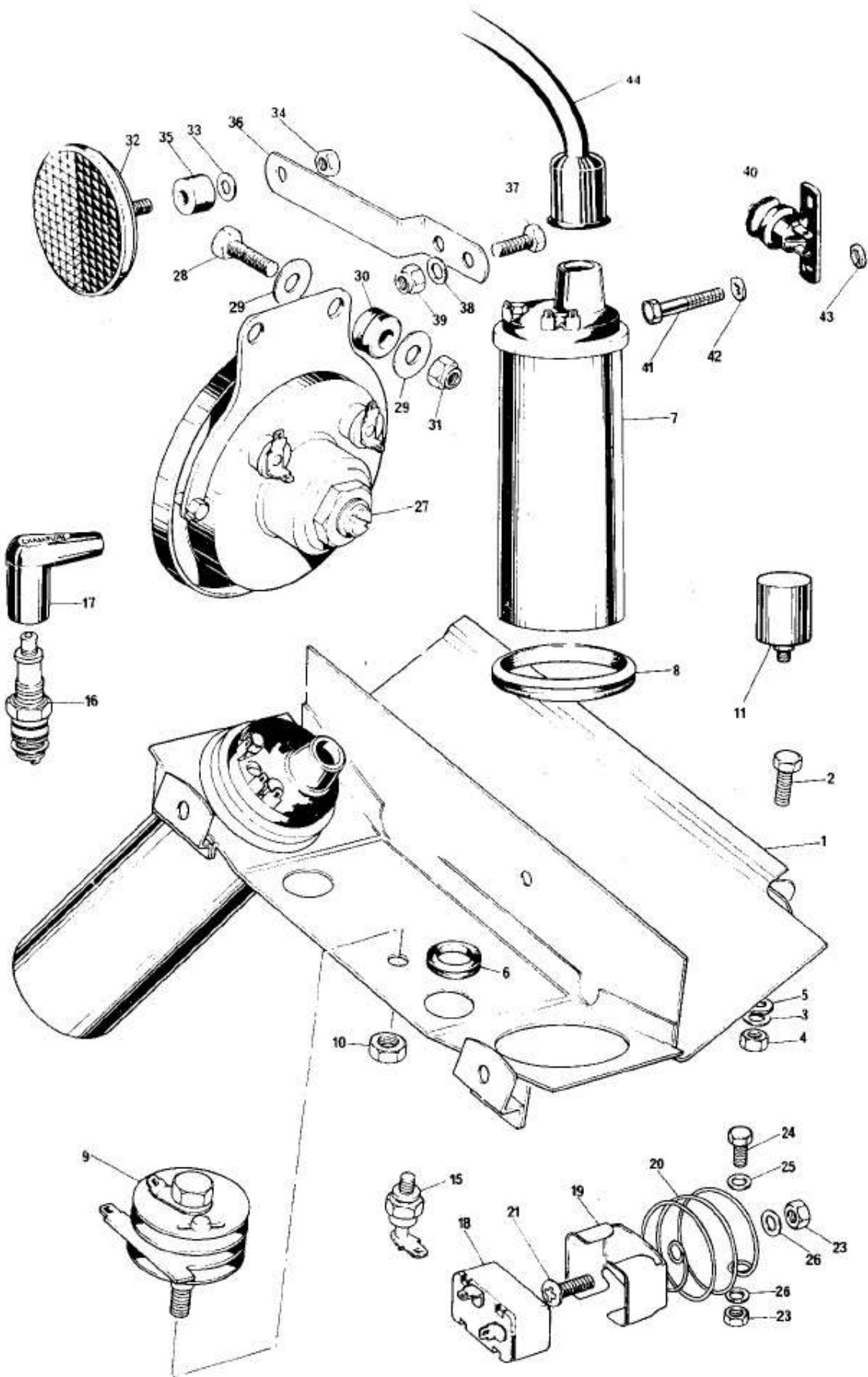

Fig. 33. COIL, CAPACITOR PACK, FLASHER UNIT, ZENER DIODE AND HORN

ELECTRICAL COMPONENTS

Ref. No.	NVT Part No.	Makers Part No.	Description	Quantity	Remarks
1	83-7041	-	Coil and tool tray assembly	1	
2	14-0102	-	Bolt	1	} Coil and tool tray attachment, rear.
3	60-2329	-	Washer	2	
4	14-1301	-	Nut	1	
5	70-7554	-	Rubber washer	1	
6	82-6784	-	Grommet, wiring harness	2	
7	60-2203	45223	Ignition coil (17-M-12)	2	
8	82-9561	-	Coil grommet	2	
9	60-0786	49072	Rectifier	1	
10	82-5338	-	Nut	1	
11	60-7018	54420128	Condenser C/ W Nut & insulating washer	2	
15	60-0987	49345	Zener diode	1	
16	60-0911	N3	Spark plug	2	CHAMPION
17	60-0262	WC200	Plug cover	2	CHAMPION
17	60-3891	MWI/10/51/10	Plug cover, suppressed (EUROPE)	2	MERIT-WORKE
18	99-1201	35048	Flasher unit	1	
19	99-1204	54385091	Clip, flasher unit	1	
20	60-3614	54386637	Spring	1	} Flasher unit attachment
21	21-2079	-	Screw	1	
22	60-2391	-	Washer	1	
23	21-7009	-	Nut	2	
24	21-2120	-	Bolt, spring to battery carrier	1	
25	97-1388	-	Plain washer	1	
26	60-2416	-	Washer	2	
27	99-1245	70228	Horn	1	} Horn attachment
28	14-0103	-	Bolt	2	
29	60-2347	-	Washer	4	
30	60-3161	-	Grommet	2	
31	14-1301	-	Nut	2	
32	99-1161	57183	Reflector - amber	2	} Reflector Mounting
33	60-2416	-	Washer	2	
34	82-3799	-	Nut	2	
35	83-3522	-	Mounting Rubber	2	
36	83-3764	-	Reflector bracket	2	
37	21-2120	-	Bolt	2	} Bracket to frame
38	60-2391	-	Washer	2	
39	21-0778	-	Nut	2	
40	99-1028	34815A	Rear stop light switch 1185A	1	
41	21-7010	-	Screw, rear stop switch	2	
42	97-1388	-	Plain washer	2	
43	83-7060	-	Rubber washer	2	
	70-4144	-	Grommet (for spark plug cover)	2	} Not illustrated
44	60-3923	-	H.T. Cable	2	

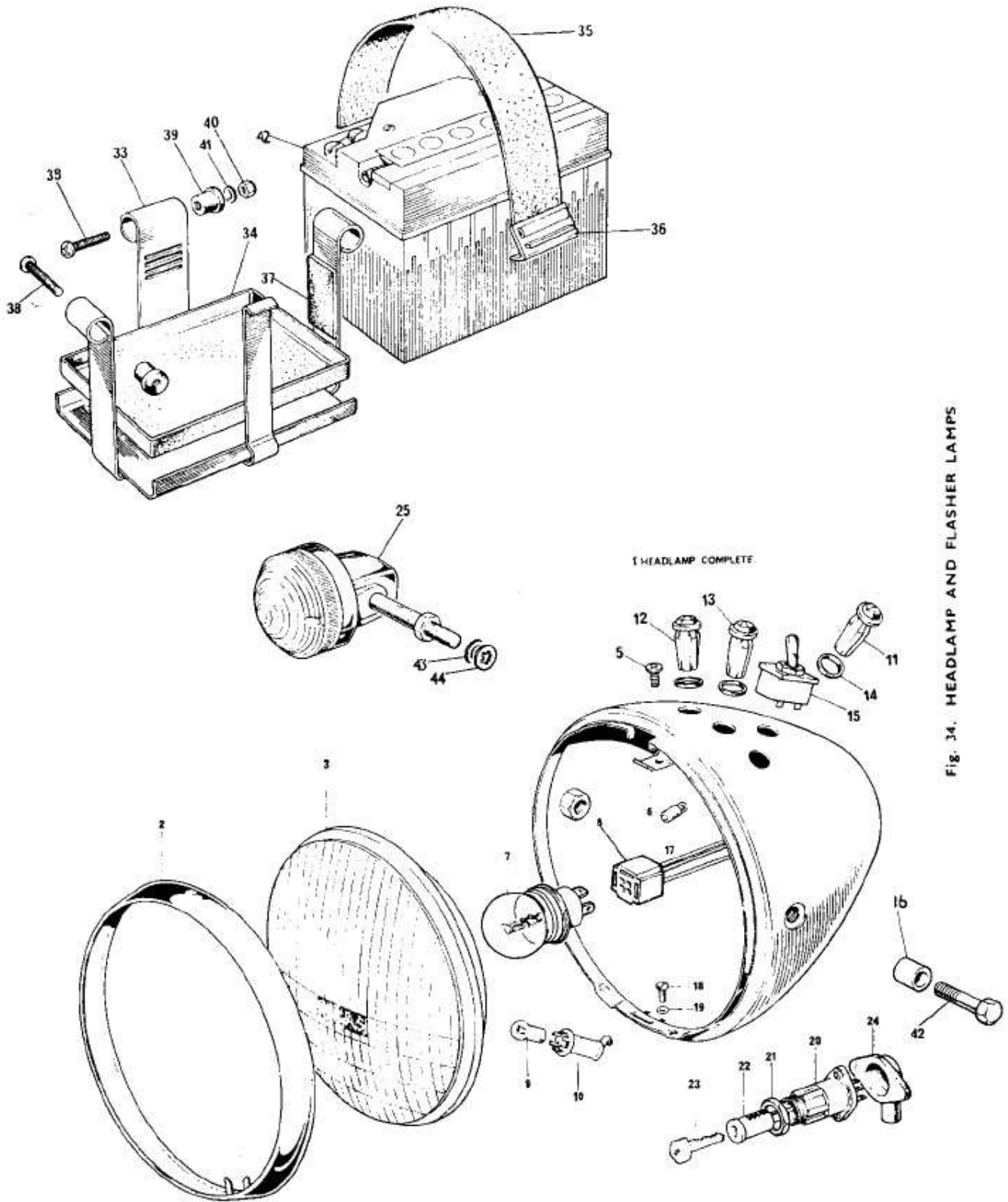

Fig. 34. HEADLAMP AND FLASHER LAMPS

HEADLAMP AND FLASHER LAMPS

Ref. No.	Part No.	Makers Part No.	Description	Quantity	Remarks
1	99-7004		Headlamp complete	1	
1	99-7005		" "	1	
2	99-0692	553248	Headlamp rim	1	
3	99-7006	54511815	Light unit	1	Left hand dip
3	99-7007	54522916	Light unit	1	Right hand dip
4	99-0683	504665	Fixing wire	6	
5	Lucas	144921	Screw	1	
6	Lucas	534296	Plate	1	
7	06-8019	410	Main bulb 45/40 w	1	
8	99-7008	54950493	Bulbholder	1	
9	99-0548	989	Pilot bulb	1	
10	99-1213	54573590	Pilot bulbholder	1	
11	99-1208	54363454	Warning light, red	1	
12	99-1209	54363455	Warning light, green	1	
13	99-1207	54363453	Warning light, amber	1	
14	99-1210	54140331	Sealing washer	3	
15	99-1251	34419	Light switch	1	
16	97-4125	-	Distance piece, headlamp bolt	2	
17	99-0537	281	Bulb, warning light	3	
18	99-1223	54115106	Screw, headlamp fixing	2	
19	99-1224	143086	Washer, headlamp fixing	2	
20	60-0989	54531899	IGNITION SWITCH	1	
21	Lucas	54130041	Nut	1	
22	82-6981	-	IGNITION LOCK WITH KEY	1	
23	60-0622	-	Ignition key	1	state serial number
24	97-2262	-	Cover, ignition switch	1	
25	60-4104		FLASHER LAMP FRONT	2	
25	60-4105		FLASHER LAMP REAR	2	
26	19-1191	54581638	Lens	1	
30	99-1192	382	Bulb	1	
31	99-1193	54123401	Screw	2	
33	83-4610	-	Battery carrier assembly	1	
34	82-8091	-	Battery tray moulding	1	
35	82-9353	-	Retaining strap	1	
36	82-9355	-	Buckle	1	
37	82-7380	-	Protective strip	4	
38	83-2508	-	Shoulder screw	3	
39	82-6039	-	Rubber bush	3	Battery carrier mounting
40	14-1301	-	Nut	1	
41	60-2329	-	Plain washer	1	
42			Bolt Headlamp mounting	2	

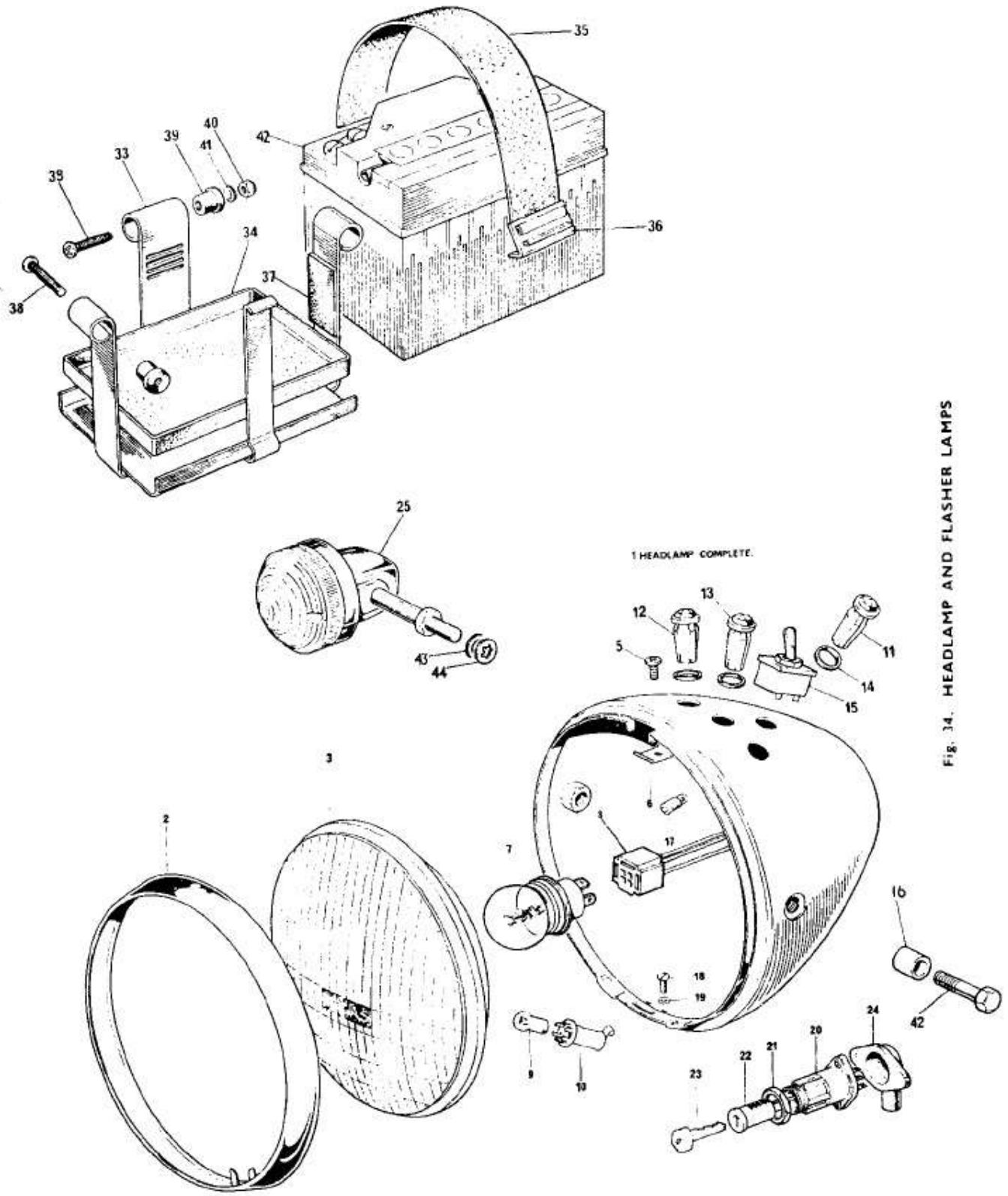

Fig. 34. HEADLAMP AND FLASHER LAMPS

Ref. No.	Part No.	Makers Part No.	Description	Quantity	Remarks
42	99-0719	54027029	Battery	1	
43	60-2332	-	Plain washer	6	} Flasher lamp stanchion
44	37-2331	-	Serrated washer	6	
45	14-0404	-	Nut	6	
	19-1962	54962258A	Main Wiring harness	1	Not illustrated
	60-7004	-	Decal, warning lights	1	Not illustrated
	60-7005	-	Decal, light switch	1	Not illustrated
	60-7003	-	Decal, ignition switch	1	Not illustrated
	60-7079		Diode & lead assy.	1	Engine start/ Lights on

**STANDARD HARDWARE SPECIFICATION
BOLTS**

Part No.	Material	Thd. dia.	Length under head	Min. length of thread	Hexagon A. F.
	Steel				
21-1822	"	5/16" UNF	1/2"	27/64"	0.500"
21-1910	"	3/8" UNF	13/16"	13/16"	0.565"
21-1919	"	5/16" UNC	1 5/8"	7/8"	0.500"
21-2010	"	1/4" UNF	13/16"	3/8"	0.375"
14-0101	"	1/4" UNF	1/2"		0.438"
14-0102	"	1/4" UNF	5/8"		0.438"
14-0103	"	1/4" UNF	3/4"		0.438"
14-0113	"	5/16" UNF	5/8"		0.500"
14-0114	"	5/16" UNF	3/4"		0.500"
14-0115	"	5/16" UNF	7/8"		0.500"
14-0128	"	3/8" UNF	1"		0.563"
14-0208	"	1/4" UNF	2 1/4"	3/4"	0.438"
14-0216	"	5/16" UNF	1 1/8"	7/8"	0.500"
14-0217	"	5/16" UNF	1 1/4"	7/8"	0.500"
14-0219	"	5/16" UNF	1 1/2"	7/8"	0.500"
14-0220	"	5/16" UNF	1 3/4"	7/8"	0.500"
14-0225	"	6/16" UNF	3"	7/8"	0.500"
14-0228	"	5/16" UNF	4"	7/8"	0.500"
14-0234	"	3/8" UNF	1 3/4"	1"	0.563"
14-0236	"	3/8" UNF	2 1/4"	1"	0.563"
14-0239	"	3/8" UNF	3"	1"	0.563"
14-0240	"	3/8" UNF	3 1/4"	1"	0.563"
14-0242	"	3/8" UNF	4"	1"	0.563"
14-0251	"	7/16" UNF	2 3/4"	1 1/4"	0.625"
14-6102	"	1/4" UNC	5/8"		0.438"
14-6115	"	5/16" UNC	7/8"		0.500"

SCREWS

Part No.	Type of head	Material	Thd. Dia.	Length under head	Type of drive
21-1916	Cheese head	Steel	1/4" UNC	1 1/8"	Cross recess
21-1917	Cheese head	"	1/4" UNC	2 5/8"	Cross recess
21-1918	Cheese head	"	1/4" UNC	2 3/8"	Cross recess
21-1920	Hex. head	"	1/4" UNC	21/64"	
21-1929	Countersunk (82°)	"	1/4" UNC	17/32"	Slot
21-2079	Cheese head	"	No. 10 UNF	1/2"	Pozidrive
14-0604	Cheese head	"	1/4" UNF	1/2"	Cross recess
14-6505	Countersunk (82°)	"	1/4" UNC	7/8"	Cross recess
14-6607	Cheese head	"	1/4" UNC	7/8"	Cross recess
14-6608	Cheese head	"	1/4" UNC	1"	Cross recess
14-6609	Cheese head	"	1/4" UNC	1 1/4"	Cross recess
14-7019	Socket head	"	5/16" UNC	7/8"	Hex. socket
14-7024	Socket head	"	5/16" UNC	2"	Hex. socket

N U T S

Part No.	Material Steel	Thd. dia.	Hexagon A.F.	Thickness	Remarks
21-0778	"	No. 10 UNF	0.375"	0.225"	Cleavelock
21-1852	"	5/16" UNF	0.437"	0.330"	Philidas
21-1906	"	1/4" UNF	0.438"	0.188"	Plain
21-1908	"	5/16" UNF	0.438"	0.313"	Plain
21-1914	"	3/4" UNEF	1.125"	0.250"	Plain
21-2012	"	7/8" UNEF	1.313"	0.438"	Plain
21-2013	"	3/4" UNEF	1.313"	0.313"	Plain
21-2014	"	3/4" UNEF	1.313"	0.438"	Plain
14-0301	"	1/4" UNF	0.438"	0.224"	Plain
14-0302	"	5/16" UNF	0.500"	0.271"	Plain
14-0401	"	1/2" UNF	0.438"	0.161"	Lock
14-0402	"	5/16" UNF	0.500"	0.192"	Lock
14-0403	"	3/8" UNF	0.563"	0.224"	Lock
14-0701	"	1/4" UNF	0.438"	0.200"	Philidas
14-0702	"	5/16" UNF	0.500"	0.246"	Philidas
14-0703	"	3/8" UNF	0.563"	0.296"	Philidas
14-1201	"	1/4" UNF	0.438"	0.285"	Stiffnut
14-1202	"	5/16" UNF	0.500"	0.335"	Stiffnut
14-1301	"	1/4" UNF	0.438"	0.245"	Stiffnut
14-1302	"	5/16" UNF	0.500"	0.290"	Stiffnut
14-1303	"	3/8" UNF	0.563"	0.320"	Stiffnut
14-1304	"	7/16" UNF	0.688"	0.275"	Stiffnut
14-1305	"	1/2" UNF	0.750"	0.435"	Stiffnut
14-1902	"	5/16" UNF	0.500"	0.361"	Nyloc
14-1903	"	3/8" UNF	0.563"	0.375"	Nyloc

W A S H E R S — P L A I N

Part No.	Material	i/dia.	o/dia.	Thickness
60-4245	Steel	0.273"	0.563"	0.048"
60-4246	Steel	0.398"	0.750"	0.063"
60-4247	Steel	0.336"	0.625"	0.063"
37-2027	Steel	0.531"	1.031"	0.092"
60-4248	Steel	0.266"	0.469"	0.064"

W A S H E R S — S P R I N G

Part No.	Material	i/dia.	o/dia.	o/a height	Thickness
60-4259	Spring steel	3/8" clearance	19/32"	7/32"	0.104"
60-4250	"	1/4" clearance	13/32"	3/16"	0.064"
60-3541	"	17/32"	7/8"	7/32"	0.040"***
21-0648	"	5/16" clearance	1/2"	5/32"	0.080"

** Double coil.

ESSENTIAL SERVICE TOOLS

Part No.	Description
60-1810	Camshaft oil seal protector
61-6019	Crankshaft pinion extractor
61-3808	Universal extractor set
61-6113	Front fork assembly tool
60-4614	5 speed gearbox assembly tool
61-6125	Gearbox sprocket spanner
61-6008	Tappet guide block punch
61-3766	Clutch extractor
61-3768	Clutch locking tool
61-6112	Piston ring clamp
60-3677	Crankshaft bearing (inner race) extractor